



**REFERENCING OF THE ESTONIAN
QUALIFICATIONS AND QUALIFICATIONS
FRAMEWORK TO THE EUROPEAN
QUALIFICATIONS FRAMEWORK**

13.09.2016

Foreword

This version of the document referencing the Estonian Qualifications Framework (EstQF) to the European Qualifications Framework for Lifelong Learning (EQF) has been developed in the process of revising the report prepared during 2008-2011. The report also self-certifies the compatibility of the Estonian Qualifications Framework for Higher Education (EstQF-HE) with the Qualifications Framework for the European Higher Education Area (QF-EHEA).

The document has been created on the basis of discussions with the EstQF and the EstQF-HE stakeholders in Estonia, and reflects major developments in the EstQF caused by changes in the legal framework during the period 2011-2014. It has been presented to the EQF Advisory Group (AG) for external evaluation of the referencing quality on 15 April 2015. The report was amended following the EQF AG recommendations.

The document was compiled by Olav Aarna, Adviser to the Management Board of the Estonian Qualifications Authority and endorsed by the EstQF Steering Committee.

Contents

Foreword	2
Abbreviations	6
Executive Summary	7
Introduction.....	13
1. The referencing process	14
1.1. Management and schedule of the process	14
1.2. Criteria and procedures of the reference quality.....	15
2. Estonian Qualifications Framework.....	18
2.1. Legal framework of the EstQF	18
2.2. Assignment of the EstQF levels to the qualifications and inclusion of qualifications into the EstQF	21
3. Referencing qualifications to the EstQF	22
3.1. Sub-framework for general education qualifications	22
3.1.1. Legal framework of general education.....	22
3.1.2. Qualification framework of general education.....	23
3.1.3. Referencing general education qualifications to the EstQF	25
3.1.4. Institutions awarding the qualification of general education and graduation requirements.....	31
3.1.5. General education qualification certificates	32
3.1.6. Recognition of prior learning in general education.....	32
3.1.7. Quality assurance in general education	33
3.2. Sub-framework of VET qualifications.....	34
3.2.1. Legal framework of VET	34
3.2.2. VET qualifications.....	34
3.2.3. VET standards.....	34
3.2.4. Assigning the EstQF level to VET qualifications	37
3.2.5. Institutions awarding VET qualifications and graduation requirements	41
3.2.6. VET qualification certificates	42
3.2.7. Recognition of prior learning in VET.....	42
3.2.8. Quality assurance system in VET.....	43
3.3. Sub-framework for higher education qualifications	45
3.3.1. Legal framework of higher education	45
3.3.2. Qualifications framework of higher education	45
3.3.3. Standard of higher education.....	46
3.3.4. Assigning EstQF level to higher education qualifications	49

3.3.5.	Institutions awarding higher education qualifications and awarding of qualifications	56
3.3.6.	Recognition of prior learning in higher education	57
3.3.7.	Qualification certificates of higher education	57
3.3.8.	Quality assurance system of higher education	58
3.3.9.	Responsibilities of national institutions	59
3.4.	Sub-framework of occupational qualifications	60
3.4.1.	Legal framework of the occupational qualifications system	60
3.4.2.	Framework of occupational qualifications	60
3.4.3.	Occupational qualification standards	62
3.4.4.	Assigning the EstQF level to occupational qualifications	62
3.4.5.	Institutions awarding occupational qualifications and awarding process	63
3.4.6.	Occupational qualification certificates	63
3.4.7.	Recognition of prior learning in awarding the occupational qualification	64
3.4.8.	Quality assurance in the system of occupational qualifications	64
Conclusions	65
Annex 1.	Composition of the Steering Committee	66
Annex 2.	Estonian formal education system	68
A2.1.	Structure and legal framework of the formal education system	68
A2.2.	General education	68
A2.3.	Vocational Education and Training	70
A2.4.	Higher education	71
A.2.5.	Estonian Education Information System	74
Annex 3.	Estonian occupational qualifications system	75
A3.1.	Legal framework of the occupational qualifications system	75
A3.2.	Institutions of the occupational qualifications system	76
A3.3.	Occupational qualification standards	77
A3.4.	Sector skills councils	78
A3.5.	Institutions awarding occupational qualifications	79
A3.6.	Occupational qualifications committees	80
A3.6.	Register of occupational qualifications	80
Annex 4.	Description of sub-frameworks referenced to the EstQF	81

A3.6. Occupational qualifications committees.....	81
A3.6. Register of occupational qualifications	81
Annex 4. Description of sub-frameworks referenced to the EstQF	82

Abbreviations

BCPC	Board of Chairpersons of Sector Skills Councils
DS	Diploma Supplement
EAP	Estonian Credit Point
ECTS	European Credit Transfer and Accumulation System
ECVET	European Credit for VET
EHEA	European Higher Education Area
EHIS	Estonian Education Information System
EKKA	Estonian Higher Education Quality Agency
EQF	European Qualifications Framework for Lifelong Learning
ESG	European Standards and Guidelines for Quality Assurance in the EHEA
EstQA	Estonian Qualifications Authority
EstQF	Estonian Qualifications Framework
EstQF-HE	Estonian Qualifications Framework for Higher Education
EstVETCP	Estonian VET Credit Point
IAOQ	Institution Awarding Occupational Qualifications
ISCED 97	International Standard Classification of Education (UNESCO, 1997)
HEI	Higher Education Institution
LO	Learning Outcome
MoER	Ministry of Education and Research
NCBC	National Curriculum for Basic Schools
NCP	National Coordination Point
NCSLD	National Curriculum for Students with Moderate and Severe Learning Disabilities
NCUSS	National Curriculum for Upper Secondary Schools
NEQC	National Examinations and Qualifications Centre
OQC	Occupational Qualifications Council
OQS	Occupational Qualification Standard
QF	Qualifications Framework
QF-EHEA	Qualifications Framework for the European Higher Education Area
RPL	Recognition of Prior Learning
SHE	Standard of Higher Education
SNCBS	Simplified National Curriculum for Basic School
SSC	Sector Skills Council
SVET	Standard of Vocational Education and Training
VET	Vocational Education and Training

Executive Summary

Creation of the Estonian Qualifications Framework (EstQF) started in 2005, when the minister of education and research established a broad-based working group with an assignment to analyse the first draft proposal of the European Qualification Framework for Lifelong Learning (EQF), the possibilities to link the Estonian five-levels occupational qualifications framework to the EQF, and formulate suggestions about the development of the EstQF. The working group put forward the proposal of creating an eight-levels comprehensive national qualifications framework. The proposal was supported by the employers' and employees' organisations, by the Estonian Chamber of Commerce and Industry, by the Ministry of Social Affairs, and by the Ministry of Economic Affairs and Communications. Based on this agreement, another broad-based working group was established by the minister of education and research with the task to draft a new Occupational Qualifications Act, which would include also the EstQF.

An eight-level qualifications framework was established in 2008, with the Occupational Qualifications Act (<http://www.kutsekoda.ee/en/kutsesysteem/oigusaktidkutseseadus>). The level descriptors of the EstQF are identical to the level descriptors of the EQF. The EstQF is a comprehensive qualifications framework, which includes qualifications awarded by the education and training institutions (general education qualifications, vocational education and training (VET) qualifications, and higher education qualifications), and occupational qualifications awarded by state recognised awarding institutions (professional associations etc.). Occupational qualification means a qualification associated with a trade, occupation or profession. Occupational qualifications can be gained through work based learning, in-service training, and adult education. Some occupational qualifications can be gained also through formal education system.

The creation and implementation of the EstQF is based on the principles for accountability and quality assurance of qualifications laid down by the European Parliament and Council recommendation on establishment of the EQF (<http://www.europarl.europa.eu/sides/getDoc.do?pubRef=-//EP//TEXT+TA+P6-TA-2007-0463+0+DOC+XML+V0//EN>).

Initially referencing of the EstQF to the EQF took place from January 2010 to August 2011. This document is an amended version of the referencing report presented to the EQF Advisory Group in September 2011 and placed into the EQF portal in July 2012. Major reason for revision of the report was adoption of the new VET Institutions Act and new Standard of VET in June 2013. This has led to VET qualifications reform reflected in this report. The report also describes other minor changes in the EstQF.

The EstQF consists of four sub-frameworks: for general education qualifications, for VET qualifications, for higher education qualifications and for occupational qualifications (see Figure 1). The referencing report is built around these four sub-frameworks. The sub-framework is described in terms of the legal framework, learning outcomes (LOs) of the qualifications involved, analysis of their compatibility with the EstQF level descriptions, recognition of prior learning (RPL), awarding of qualifications, and their quality assurance.

The steering committee established by the minister of education and research arrived at the conclusion that the referencing of four sub-frameworks of qualifications to the EstQF and referencing it to the EQF follows all the rules, procedures and quality criteria that have been agreed upon in the European Union (<http://www.europarl.europa.eu/sides/getDoc.do?pubRef=-//EP//TEXT+TA+P6-TA-2007-0463+0+DOC+XML+V0//EN>). Table 1 presents the results of assigning the EstQF levels to Estonian formal education qualifications, and examples of occupational qualifications on different levels. The state register of occupational qualifications includes 545 occupational qualifications (<http://www.kutsekoda.ee/en/kutseregister>). Examples of occupational qualification standards in English can be found on the Estonian Qualifications Authority's (EQA) web page: http://www.kutsekoda.ee/en/kutsesysteem/tutvustus/kutsestandardid_eng.

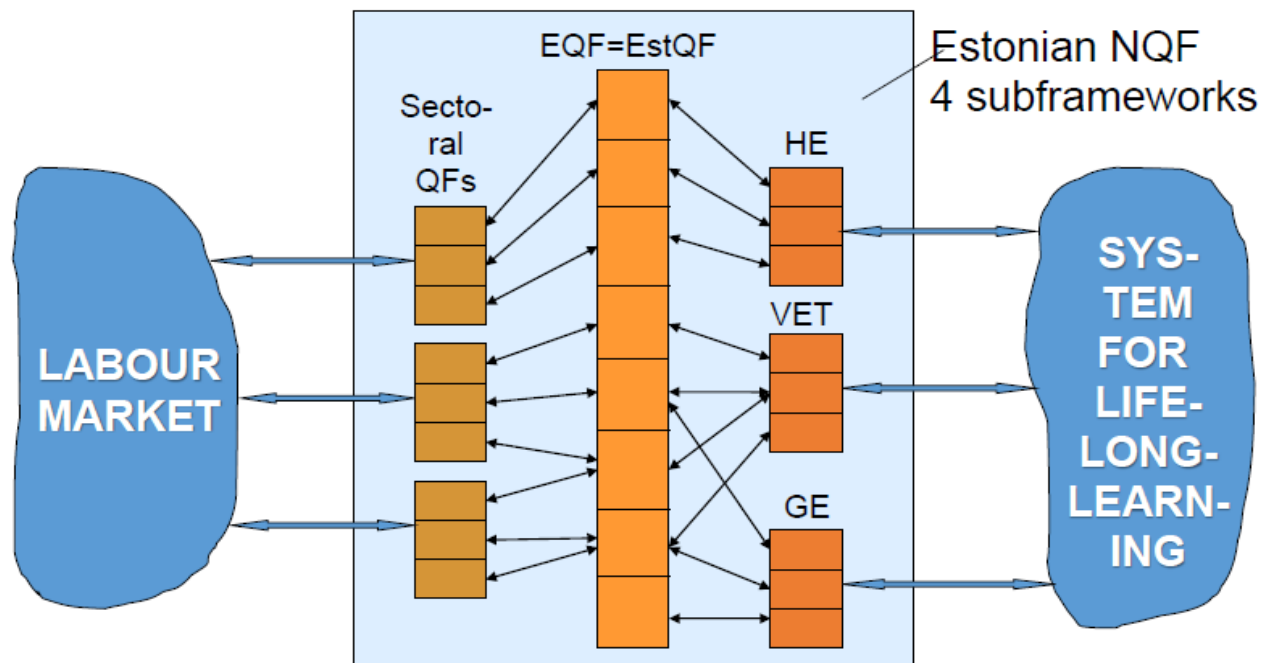

HE – higher education qualifications sub-framework

VET – VET qualifications sub-framework

GE – general education qualifications sub-framework

Sectoral qualifications frameworks comprise the occupational qualifications framework

Figure 1. Structure of the EstQF

This document serves also as a Bologna self-certification report. The working group established by the Ministry of Education and Research (MoER) arrived at the conclusion that the Estonian Qualifications Framework for Higher Education (EstQF-HE) is compatible with the Framework for Qualifications of the European Higher Education Area (FQ-EHEA) and fulfils all the Bologna self-certification criteria and procedures <http://www.ehea.info/>. References to the respective Bologna self-certification criteria and procedures are given in the body text of the report.

Table 1. Placement of formal education qualifications and occupational qualifications in the EstQF

Formal education qualifications	EstQF levels	Examples of occupational qualifications
Basic education certificate based on curriculum for students with moderate and severe learning disabilities	1	
Basic education certificate based on simplified curriculum Basic education certificate VET qualification certificate, level 2	2	Assistant gardener, Logger
VET qualification certificate, level 3	3	Electronic equipment assembler, Woodworking bench operator
Upper secondary general education certificate Upper secondary VET certificate VET qualification certificate, level 4	4	Harvester operator, Veterinary assistant
VET qualification certificate, level 5	5	Biogas plant operator, Mechatronic-

		technician
Diploma of Bachelor's degree, Diploma of professional higher education	6	Physiotherapist, Civil Engineer, Applied Architect
Diploma of Master's degree	7	Diploma engineer, Diploma architect
Diploma of Doctoral degree	8	Chartered civil engineer, Chartered architect

Since the level descriptions of the EstQF are identical with those of the EQF, the quality of referencing the qualifications from the four sub-frameworks to the EstQF is critical. Therefore, the criteria for referencing the EstQF to the EQF are defined in terms of the placement of qualifications to the EstQF:

- 1) *The responsibilities and/or legal competence of all relevant national bodies involved in the referencing process, including the National Coordination Points (NCP), are clearly determined and published by the competent public authorities.*

The Estonian Qualifications Authority (EstQA) was nominated as the NCP for the EQF implementation in Estonia with the 26.02.2010 decision of the MoER. This information is presented on the EstQA website www.kutsekoda.ee. In order to ensure the involvement of all key stakeholders in these processes, a broad-based steering committee was established with the 4.10.2010 order of the minister of education and research. The steering committee includes representatives of competent national bodies and stakeholders: the MoER, the Ministry of Finance, the Ministry of Social Affairs, the State Chancellery, Estonian Chamber of Commerce and Industry, EstQA, Confederation of Estonian Trade Unions, Public Servants Trade Unions Central Organization TALO, Estonian Association of Student Unions, Estonian Association of Pupils' Unions, Estonian ENIC/NARIC Centre. Initially, a separate working group was established to prepare the Bologna self-certification report. With the 9.08.2011 order of the minister of education and research the steering committee for the EQF referencing was amended to include additional representatives of the higher education sector.

- 2) *There is a clear and demonstrable link between the qualification level descriptions and the level descriptors of the EstQF.*

According to the Occupational Qualifications Act, the EstQF has 8 levels, the 1st of which is the lowest and the 8th is the highest. The descriptions of the EstQF qualification levels are identical to the EQF level descriptions. The sub-frameworks for general education qualifications, VET qualifications, higher education qualifications, and occupational qualifications contain more detailed and specific descriptors and rules for designing and awarding qualifications. The EstQF levels are assigned to general education qualifications (on levels 1,2 and 4), VET qualifications (on levels 2-5), higher education qualifications (on levels 6-8), and occupational qualifications (on levels 2-8) (see Figure 2). Learning outcomes (LOs) based descriptions of these types of qualifications have been compared with level descriptions of the EstQF and the best fit found.

- 3) *The qualifications are based on the principle and objective of learning outcomes and linked to arrangements for validation of non-formal and informal learning and, where these exist, to credit systems.*

The qualifications of general education, VET, and higher education are described in terms of LOs. For all the aforementioned qualification types, the principles of recognition of non-formal and informal learning are defined in the relevant regulations of the Government of the Republic (National Curriculum for Basic Schools, Simplified National Curriculum for Basic Schools, National Curriculum for Upper Secondary Schools, Standard of VET, and Standard of Higher Education). On the basis of these principles the awarding institutions shall establish the procedures for RPL. In higher education, a credit point system, which conforms to the ECTS, is used. In the VET sector a credit point system that conforms to the ECVET, is used.

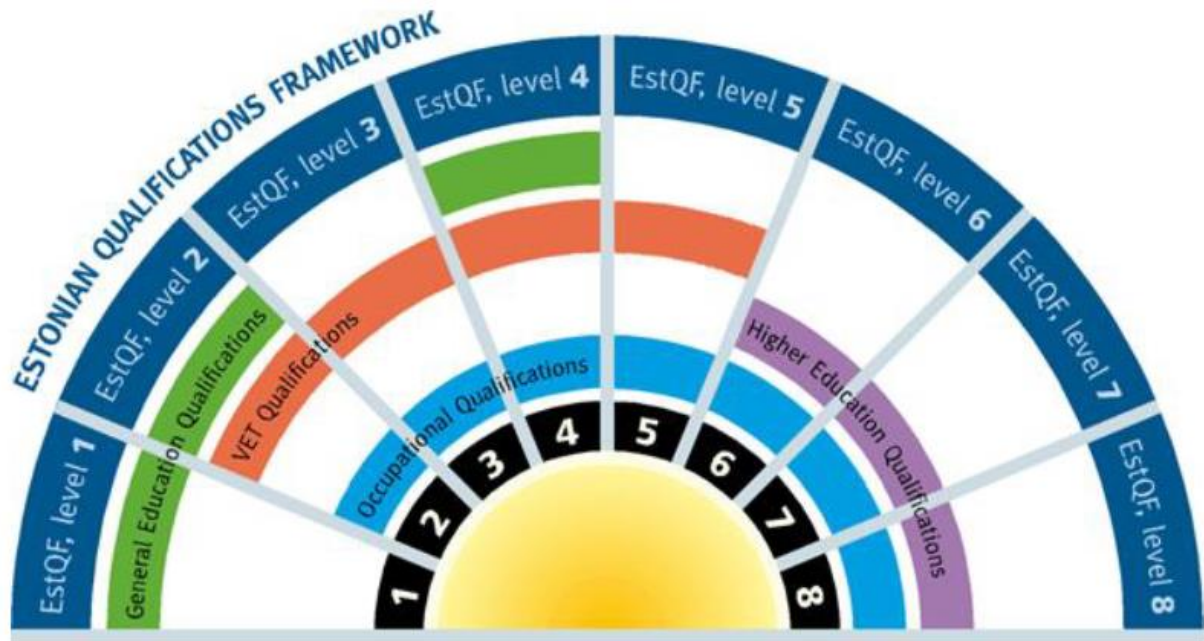

Figure 2. Placement of qualifications in the EstQF

- 4) *The procedures for inclusion of qualifications in the EstQF or for describing the place of qualifications in the EstQF are transparent.*

Referencing general education, VET and higher education qualifications to the EstQF levels has been laid down in the relevant regulations of the Government of the Republic (National Curriculum for Basic Schools, Simplified National Curriculum for Basic Schools, National Curriculum for Upper Secondary Schools, Standard of VET, and Standard of Higher Education). Representatives of stakeholders were involved in developing all of the aforementioned regulations. The EstQF levels of occupational qualifications are determined in the process of developing the corresponding occupational qualification standards and laid down by a corresponding decision of the sector skills council (SSC).

The EstQF shall include qualifications that meet the following criteria: they are defined in a LOs based qualification standard (curriculum or occupational qualification standard), meeting the requirements of the national framework standard(s) (if applicable); they are awarded by a state recognised institution (educational institution or an institution awarding occupational qualifications (IAOQ)).

- 5) *The national quality assurance system(s) for education and training refer(s) to the EstQF and are consistent with the relevant European principles and guidelines (see Clause 2.2).*

In the general education system, a quality assurance system stipulated by the Basic Schools and Upper Secondary Schools Act has been implemented. In general education schools as awarders of qualification, self-assessment systems are created, the effectiveness of which is regularly assessed. External evaluation of general education qualifications includes state examinations in the end of upper secondary school.

In the VET system, a quality assurance system stipulated by the VET Institutions Act has been implemented. Since September 2013 a new quality assurance system for VET qualifications, following the principles of European Quality Assurance Reference Framework for VET is implemented. In the new system the duties of a quality agency are carried out by the Estonian Quality Agency for Higher and Vocational Education (EKKA) (<http://ekka.archimedes.ee/en/>).

In the higher education system, a comprehensive quality assurance system that follows the European Standards and Guidelines for Quality Assurance in the European Higher Education Area (ESG) has been implemented based on the Universities Act and the Institutions of Professional Higher Education Act. The duties of a quality agency are carried out by the EKKA. The responsibilities of the EKKA and the main principles of external quality assurance are in full accordance with the ESG. The EKKA has been included into the [European Quality Assurance Register for Higher Education](#) (EQAR) in October 2013.

In higher education institutions as awarders of qualifications, comprehensive quality assurance systems have been created. The effectiveness of internal quality assurance systems is assessed regularly in the process of institutional accreditation that was piloted in 2011 and is fully functioning since 2012.

The principles and procedures for ensuring the quality in the occupational qualifications system have been laid down by the Occupational Qualifications Act, which follows the requirements of ISO 17924 (General requirements for certification of persons). Quality assurance in the occupational qualifications system involves: quality assurance of granting an institution awarding occupational qualification (IAOQ) the right to award occupational qualifications, quality assurance of occupational qualification standards, assessment of the quality of assessing the competence of applicants by the IAOQ, and regular external evaluation of IAOQ.

6) *The referencing process shall include the stated agreement of the relevant quality assurance bodies.*

In the case of general education qualifications, the quality assurance institution is the MoER. The reference of general education qualifications to the EstQF has been laid down in the National Curriculum for Basic Schools, Simplified National Curriculum for Basic Schools and the National Curriculum for Upper Secondary Schools.

In the case of VET qualifications, the quality assurance institution is the EKKA. The reference of VET qualifications to the EstQF has been laid down in the Standard of VET.

In the case of higher education qualifications, the quality assurance institution is the EKKA. The reference of higher education qualifications to the EstQF has been laid down in the Standard of Higher Education.

In the case of occupational qualifications, the quality assurance institution is the EstQA. The reference of specific occupational qualifications to the EstQF is decided by the Sector Skills Council (SSC) of the relevant field of occupational activity. According to the Occupational Qualifications Act, the EstQA monitors the activities of SSC-s.

All the above mentioned quality assurance bodies have been represented in the steering committee for governing the referencing process.

7) *The referencing process shall involve international experts.*

The following persons were involved in the referencing process of the EstQF to the EQF: Carita Blomqvist (Finland), Margaret Cameron (UK) and Baiba Ramina (Latvia). International experts participated in the referencing process starting from December 2010, when they received the first version of the referencing report. In February 2011 oneday meeting was held with international experts, where the steering committee discussed comments and suggestions of experts. These included particularly explanation of the logic behind the structure of EstQF and placement of general education qualifications. International experts had also a possibility to comment the final version of the report in August 2011. No international expertise has been used in preparing this report.

8) *The competent national body or bodies shall certify the referencing of the national qualifications with the EstQF. One comprehensive report, setting out the referencing and the evidence supporting it, shall be published by the competent national bodies, including the NCP, and shall address separately each of the criteria (LO descriptors).*

This report is a summary of assigning EstQF level to all types of Estonian qualifications with the relevant supporting evidence. The report has been approved by the steering committee including representatives of competent national bodies and stakeholders.

The reference of general education qualifications to the EstQF has been laid down in three regulations of the Government of the Republic: National Curriculum for Basic Schools, Simplified National Curriculum for Basic Schools and National Curriculum for Upper Secondary Schools. The summary of an analysis based on the types of LOs is presented in the report.

The reference of VET qualifications to the EstQF has been laid down in the Government of the Republic regulation: VET Standard. The summary of an analysis based on the types of LOs is presented in report.

The reference of higher education qualifications to the EstQF has been laid down in the Government of the Republic regulation: Higher Education Standard. The summary of an analysis based on the types of LOs is presented in the report.

The reference of occupational qualifications to the EstQF is determined by the SSC of the relevant occupational field. This information is presented in the register of occupational qualifications (www.kutsekoda.ee). The methodology of the analysis based on the types of LOs is presented in the report.

- 9) *The official EQF platform shall maintain a public listing of member states that have confirmed that they have completed the referencing process, including links to completed referencing reports.*

Estonia completed the referencing process of its qualifications to the EQF and obtained a confirmation on the positive result of the external evaluation by the EQF Advisory Group in October 2011. This report has subsequently been included into the EQF official platform including examples of qualifications.

The report in Estonian and English has also been published on the web site of the MoER (<http://www.hm.ee>), on the website of the EstQA (<http://www.kutsekoda.ee>) and on the website of the Estonian ENIC/NARIC Centre (<http://www.archimedes.ee/enic>).

- 10) *Following the referencing process, all new qualification certificates, diplomas and Europass documents issued by the competent authorities contain a clear reference to the appropriate EstQF level.*

Starting from 2012 institutions awarding higher education qualifications and occupational qualifications are adding a reference to the corresponding EQF and EstQF level to the issued qualification certificates, diplomas and Europass documents, incl. academic transcripts and Diploma Supplements, provided that the corresponding qualification meets all the requirements for inclusion into the EstQF. Since September 2013 institutions awarding VET qualifications are adding a reference to the corresponding EQF and EstQF level to the issued qualification certificates. Since May 2014 institutions awarding general education qualifications are adding a reference to the corresponding EQF and EstQF level to the issued qualification certificates.

Introduction

In 2000, the European Council adopted the **Lisbon Strategy**, aimed at making the EU the most competitive and dynamic knowledge-based economy in the world, characterised by constant economic growth, creation of new and better jobs and larger social coherence. An important part of this strategy is to **develop the common European lifelong learning area, and relevant systems of lifelong learning in the Member States**. In the field of higher education, this idea is realized through the Bologna process, and in VET, through the Copenhagen process.

An important process in the creation of the common European lifelong learning area is the development and implementation of the European Qualifications Framework for Lifelong Learning (EQF). The **learning outcomes based approach** is the core of the EQF. On April 23, 2008, the European Parliament and Council adopted a **recommendation on establishment of the EQF** (<http://www.europarl.europa.eu/sides/getDoc.do?pubRef=-//EP//TEXT+TA+P6-TA-2007-0463+0+DOC+XML+V0//EN>). In this context qualification is understood as a result of official assessment and validation of competence. The EQF has **8 qualification levels, in which qualification is described in terms of learning outcomes**, expressed in three categories: **knowledge, skills and competence** (understood as the degree of autonomy and responsibility). The first step in implementing the EQF is referencing national qualifications framework (hereinafter NQF) levels or national qualifications to the EQF levels.

The EQF is a reference framework of different formal education qualifications (general education, vocational education and training, higher education) and occupational qualifications (sectoral qualifications). The EQF links the qualification systems of the EU Member States and makes qualifications of different countries more mutually understandable and comparable. An important objective is to also **recognise the results of non-formal and informal learning**. Creation of NQF is seen as an important mean in achieving these objectives. Although establishing NQF is not mandatory, most of the EU Member States have chosen this method.

Referencing qualifications to the EQF has been envisaged as a two-stage process:

- by 2010, the Member States had to reference their NQF to the EQF;
- starting from 2012, the member states have to add a reference to the corresponding EQF level to each qualification certificate and diploma supplement.

Referencing national qualifications and qualifications frameworks to the EQF is based on the **best fit principle**. This means reliable decision, to which EQF level a particular qualification or level of the qualification framework fits best. Because of the structure of the EQF level descriptors the application of this principle has two dimensions:

- the best fit with the EQF level for the NQF level or qualification;
- the best fit with the type of the given LO (knowledge, skills, scope of autonomy and responsibility).

The EQF is a voluntary initiative and is based on mutual trust between the member states. The EQF Advisory Group has proposed **10 quality criteria and procedures** for referencing NQF to the EQF (<http://ec.europa.eu/transparency/regexpert/index.cfm?do=groupDetail.groupDetailDoc&id=10973&no=2>). These criteria and procedures serve as guidelines for the member states that wish to participate in the process of the EQF implementation and using them helps to do it in transparent and coherent manner.

1. The referencing process

1.1. Management and schedule of the process

In order to coordinate the development and implementation of NQF-s and to ensure the quality of referencing with the EQF, the EU Member States are advised to establish a **National Coordination Point** (NCP). In Estonia, it is the role of the **Estonian Qualifications Authority (EstQA)**. The EstQA was nominated as the NCP for the EQF implementation in Estonia with the 26.02.2010 decision of the Ministry of Education and Research (MoER). This information is presented on the EstQA website www.kutsekoda.ee.

In order to ensure the involvement of all key stakeholders in the process of referencing the Estonian Qualifications Framework (EstQF) to EQF, a broad-based **steering committee** was established with the 4.10.2010 order of the minister of education and research. The steering committee includes representatives of competent national bodies and stakeholders: the MoER, the Ministry of Finance, the Ministry of Social Affairs, the State Chancellery, Estonian Chamber of Commerce and Industry, EstQA, Confederation of Estonian Trade Unions, Public Servants Trade Unions Central Organization TALO, Estonian Association of Student Unions, Estonian Association of Pupils' Unions, Estonian ENIC/NARIC Centre. The make-up of the steering committee is presented in Annex 1.

Initially, a separate steering committee was established to prepare the Bologna self-certification report. The make-up of this steering committee is also presented in Annex 1. With the 9.08.2011 order of the minister of education and research the steering committee for the EQF referencing was amended to include additional representatives of the higher education sector. The formation of the steering committee meets the **Criterion 1 as well as the Procedures 1 and 2 of the QF-EHEA**.

The main stages of developing the EstQF and referencing Estonian qualifications to the EQF were:

- 1) The EstQF was established with the Occupational Qualifications Act (<https://www.riigiteataja.ee/akt/13147615>) (01.09.2008).
- 2) Descriptions of the LOs for the higher education qualifications were provided in the Standard of Higher Education (<https://www.riigiteataja.ee/akt/13099603?leiaKehtiv>) (December 2008) (**Criterion 3 of the QF-EHEA**).
- 3) Descriptions of the LOs for the vocational education and training (VET) qualifications were provided in the Standard of VET (SVET) (December 2008) and replaced by the new SVET in September 2013 (<https://www.riigiteataja.ee/akt/128082013013>) (December 2008).
- 4) Descriptions of the LOs for the general education qualifications were provided in the National Curriculum for Basic Schools (<https://www.riigiteataja.ee/akt/114012011001?leiaKehtiv>), in the National Curriculum for Upper Secondary Schools (<https://www.riigiteataja.ee/akt/114012011001?leiaKehtiv>) and in the Simplified National Curriculum for Basic Schools (<https://www.riigiteataja.ee/akt/114012011002?leiaKehtiv>) (January 2010).
- 5) LOs based (competence-based) descriptions of occupational qualifications were prepared and referenced to the EstQF (2007–2014) (<http://www.kutsekoda.ee/et/kutseregister>).
- 6) The process of referencing the EstQF to the EQF was initiated (January 2010).
- 7) EstQA was appointed as the national coordination point for implementation of the EQF in Estonia (February 2010).
- 8) The first version of the referencing report was prepared (May–November 2010).
- 9) Referencing report was discussed with stakeholders (December 2010–March 2011).
- 10) International experts: **Carita Blomqvist** (Finland), **Margaret Cameron** (UK) and **Baiba Ramina** (Latvia) were involved (December 2010–August 2011) (**Procedure 3 of the QF-EHEA**).
- 11) Final version of the referencing report was prepared (May-August 2011).

- 12) Referencing report was submitted to the EQF Advisory Group (September 2011).
- 13) Referencing report was presented to the EQF Advisory Group (October 2011).
- 14) Referencing report was placed into the EQF portal (July 2012).
- 15) International launching conference for the EstQF was organised (October 2012).
- 16) Referencing report was revised and amended (September-November 2014).
- 17) Referencing report was endorsed by the EstQF steering committee (March 2015).
- 18) Referencing report was presented to the EQF Advisory Group (April 2015).

1.2. Criteria and procedures of the reference quality

The EQF recommendation encourages member states to reference the national qualifications or levels of qualification framework to the EQF levels by 2010. In order to ensure the involvement of the process in a reliable and understandable manner for the stakeholders of all the countries involved in the process, the EQF Advisory Group has agreed upon the procedures and criteria necessary for managing this process.

The aim of these **criteria and procedures** is to ensure that information and documentation that are made accessible to the public are approved by competent authorities and they are appropriate, transparent, comparable and reliable. Such an emphasis shows that the success of the EQF implementation depends on whether the countries are able to reference their qualifications and levels to the EQF levels in a justified, clear and reasonable way. It means that people who are not familiar with the qualifications in a member state would be able to assess whether or not the information is correct.

The criteria for referencing to the EQF are as follows:

- 1) The responsibilities and/or legal competence of all relevant national bodies involved in the referencing process, including the NCP, are clearly determined and published by the competent public authorities.
- 2) There is a clear and demonstrable link between the sub-frameworks qualification descriptions and the level descriptors of the EQF.
- 3) The qualifications are based on the principle and objective of learning outcomes and linked to arrangements for validation of non-formal and informal learning and, where these exist, to credit systems.
- 4) The procedures for inclusion of qualifications in the EQF or for describing the place of qualifications in the EQF are transparent.
- 5) The national quality assurance system(s) for education and training refer(s) to the EQR and are consistent with the relevant European principles and guidelines (as indicated in annex 3 of the Recommendation).
- 6) The referencing process shall include the stated agreement of the relevant quality assurance bodies.
- 7) The referencing process shall involve international experts.
- 8) The competent national body or bodies shall certify the referencing of the national qualifications with the EQF. One comprehensive report, setting out the referencing and the evidence supporting it shall be published by the competent national bodies, including the NCP, and shall address separately each of the criteria (learning outcomes descriptors).
- 9) The official EQF platform shall maintain a public listing of member states that have confirmed that they have completed the referencing process, including links to completed referencing reports.
- 10) Following the referencing process, and in line with the timelines set in the Recommendation, all new qualification certificates, diplomas and Europass documents issued by the competent authorities contain a clear reference, by way of national qualifications systems, to the appropriate EQF level.

Since EstQF contains four qualifications sub-frameworks and the level descriptions of the EstQF are identical with those of the EQF, the criteria for referencing the EstQF to the EQF have been reformulated in the terms of assigning EstQF levels to the qualifications and the placement of qualifications to the EstQF (see Executive Summary). Qualifications sub-frameworks are described in the corresponding legal acts and contain sub-framework specific LOs based descriptions of qualification levels?

The European Parliament and Council recommendation on establishment of the EQF also includes the **principles for accountability and quality assurance of qualifications** (<http://www.europarl.europa.eu/sides/getDoc.do?pubRef=-//EP//TEXT+TA+P6-TA-2007-0463+0+DOC+XML+V0//EN>):

- 1) Quality assurance policies and procedures should underpin all levels of the EQF.
- 2) Quality assurance should be an integral part of the internal management of educational institutions.
- 3) Quality assurance should include regular evaluation of institutions, their programmes or their quality assurance systems by external monitoring bodies or agencies.
- 4) External monitoring bodies or agencies carrying out quality assurance should be subject to regular review.
- 5) Quality assurance should include context, input, process and output dimensions, while giving emphasis to outputs and learning outcomes.
- 6) Quality assurance systems should include the following elements:
 - clear and measurable objectives and standards,
 - guidelines for implementation, including stakeholder involvement,
 - appropriate resources,
 - consistent evaluation methods, associating self-assessment and external review,
 - feedback mechanisms and procedures for improvement,
 - widely accessible evaluation results.
- 7) Quality assurance initiatives at international, national and regional level should be coordinated in order to ensure overview, coherence, synergy and system-wide analysis.
- 8) Quality assurance should be a cooperative process across education and training levels and systems, involving all relevant stakeholders, within Member States and across the Community.
- 9) Quality assurance orientations at Community level may provide reference points for evaluations and peer-learning.

The following **criteria** have been proposed **for the verification that national frameworks for higher education are compatible with the European Higher Education Area (EHEA) framework** (<http://www.ehea.info/>):

- 1) The national framework for higher education qualifications and the body or bodies responsible for its development are designated by the national ministry with responsibility for higher education;
- 2) There is a clear and demonstrable link between the qualifications in the national framework and the cycle qualification descriptors of the European framework;
- 3) The national framework and its qualifications are demonstrably based on learning outcomes and the qualifications are linked to ECTS credits;
- 4) The procedures for inclusion of qualifications in the national framework are transparent;
- 5) The national quality assurance system for higher education refer to the national framework for higher education qualifications and are consistent with the Berlin Communiqué and any subsequent Ministerial Communiqués in the Bologna Process;
- 6) The national framework, and any alignment with the European framework, is referenced in all Diploma Supplements;
- 7) The responsibilities of the domestic parties to the national framework are clearly determined and

published.

It has been proposed that each country should certify the compatibility of its own framework with the overarching framework according to the following **procedures**:

- 1) The competent national body/bodies shall self-certify the compatibility of the national framework with the European framework;
- 2) The self-certification process shall include the stated agreement of the quality assurance bodies of the country in question recognised through the Bologna Process;
- 3) The self-certification process shall involve international experts;
- 4) The self-certification and the evidence supporting it shall address separately each of the criteria established and shall be published;
- 5) The ENIC/NARIC network shall maintain a public listing of States that have completed the self-certification process;
- 6) The completion of the self-certification process shall be noted on Diploma Supplements issued subsequently by showing the link between the national framework and the European framework.

Although criteria and procedures for the EQF referencing differ from the criteria and procedures for the Bologna self-certification process, they are fully compatible by content. All criteria and procedures are referenced in the text of the report.

2. Estonian Qualifications Framework

2.1. Legal framework of the EstQF

According to the Occupational Qualifications Act (<http://www.kutsekoda.ee/en/kutsesysteem/oigusaktidkutseseadus>), the EstQF has **eight levels**, the first of which is the lowest and the eighth is the highest. The descriptions of the qualification levels are **identical with the EQF level descriptions**. EstQF is a comprehensive framework, consisting of four sub-frameworks for:

- General education qualifications,
- VET qualifications,
- Higher education qualifications,
- Occupational qualifications.

An EstQF level is assigned to each of the qualification in these sub-frameworks.

Descriptions of qualifications in sub-frameworks are defined in the corresponding national educational standards:

- National Curriculum for Basic Schools,
- Simplified National Curriculum for Basic Schools,
- National Curriculum for Upper Secondary Schools,
- Standard of VET,
- Standard of Higher Education,
- Occupational qualification standards.

The table in Annex 4 presents LOs of all sub-frameworks referenced to the EstQF.

The EstQF level descriptions are presented in Table 2.1. The level descriptions of the EstQF determine the general requirements for the LOs of the general education qualifications, VET qualifications, higher education qualifications, and occupational qualifications.

Table 2.1. Estonian Qualifications Framework level descriptions

EstQF level	Knowledge (<i>described as theoretical and/or factual</i>)	Skills (<i>described as cognitive: involving the use of logical, intuitive and creative thinking, and practical: involving manual dexterity and the use of methods, materials, tools and instruments</i>)	Scope of responsibility and autonomy
Level 1	Basic general knowledge	Basic skills required to carry out simple tasks	Work or study under direct supervision in a structured content
Level 2	Basic factual knowledge of a field of work or study	Basic cognitive and practical skills required to use relevant information in order to carry out tasks and to solve routine problems using simple rules and tools	Work and study under supervision with some autonomy
Level 3	Knowledge of facts, principles, processes and general concepts, in a field of work or study	A range of cognitive and practical skills required to accomplish tasks and solve problems by selecting and applying basic methods, tools, materials and information	Take responsibility for completion of tasks in work or study; Adapt own behaviour to circumstances in solving problems

Level 4	Factual and theoretical knowledge in broad contexts within a field of work or study	A range of cognitive and practical skills required to generate solutions to specific problems in a field of work or study	Exercise self-management within the guidelines of work or study contexts that are usually predictable, but are subject to change supervise the routine work of others, taking some responsibility for the evaluation and improvement of work or study activities
Level 5	Specialised, factual and theoretical knowledge within a field of work or study and an awareness of the boundaries of that knowledge	A comprehensive range of cognitive and practical skills required to develop creative solutions to abstract problems	Exercise management and supervision in contexts of work or study activities where there is unpredictable change; Review and develop performance of self and others
Level 6	Advanced knowledge of a field of work or study, involving a critical understanding of theories and principles	Advanced skills, demonstrating mastery and innovation, required to solve complex and unpredictable problems in a specialised field of work or study	Manage complex technical or professional activities or projects, taking responsibility for decision-making in unpredictable work or study contexts; Take responsibility for managing professional development of individuals and groups
Level 7	Highly specialised knowledge; some of which is at the forefront of knowledge in the field of work or study, as the basis for original thinking and/or research critical awareness of knowledge issues in a field and at the interface between different fields	Specialised problem-solving skills required in research and/or innovation in order to develop new knowledge and procedures and to integrate knowledge from different fields	Manage and transform work or study contexts that are complex, unpredictable and require new strategic approaches; Take responsibility for contributing to professional knowledge and practice and/or for reviewing the strategic performance of teams
Level 8	Knowledge at the most advanced frontier in the field of work or study and at the interface between fields	The most advanced and specialised skills and techniques, including synthesis and evaluation, required to solve critical problems in research and/or innovation and to extend and redefine existing knowledge or professional practice	Demonstrate substantial authority, innovation, autonomy, scholarly and professional integrity and sustained commitment to the development of new ideas or processes at the forefront of work or study contexts including research

2.2. Assignment of the EstQF levels to the qualifications and inclusion of qualifications into the EstQF

The quality criteria and procedures for referencing the NQF to the EQF foresee two types of referencing: “including into the NQF” and “describing the position in the NQF”. In the context of Estonia these two ways of referencing are called correspondingly **including a qualification into the EstQF** and **assigning the EstQF levels to a qualification**.

Only **state recognised qualifications** are **included into the EstQF**. Actually, a qualification is included in one of the sub-frameworks of the EstQF. The state recognised qualifications are:

- defined in a **LOs based qualification standard** (framework standard for a qualification type, national curriculum or occupational qualifications standard), meeting the requirements of the national framework standard(s) (if applicable),
- have **state recognised awarding institution** (educational institution, professional association etc.), i.e. be quality assured.

Since the EstQF level descriptions are identical to the EQF level descriptions, the centre of gravity of the referencing process is shifted to **assigning of the EstQF levels to a qualification**. Therefore, assigning appropriate EstQF levels to the qualifications and including the state recognised qualifications into the EstQF have to follow the principles and criteria formulated in p.1.2.

Chapter 3 explains how the aforementioned principles have been implemented in assigning EstQF level to the general education qualifications, VET qualifications, higher education qualifications and occupational qualifications, and in including the corresponding qualifications into the EstQF. Also, ensuring the quality of these processes for the different types of qualifications is described.

EstQF is the central part of the Estonian qualifications system. Four important processes take place in the qualifications system, the quality of which determines the efficiency and reliability of the whole system:

- Development of qualification standards (framework standards for types of qualifications, occupational qualifications standards, national curricula);
- Assigning the EstQF levels to qualifications;
- Including qualifications into the EstQF;
- Assessment of persons' competence.

3. Referencing qualifications to the EstQF

Qualifications are included in the sub-frameworks of the EstQF:

- Sub-framework for general education qualifications,
- Sub-framework for VET qualifications,
- Sub-framework for higher education qualifications,
- Sub-framework for occupational qualifications.

3.1. Sub-framework for general education qualifications

3.1.1. Legal framework of general education

The legal framework of general education consists of:

- Republic of Estonia Education Act (<https://www.riigiteataja.ee/akt/13198443?leiaKehtiv>);
- Pre-School Childcare Institutions Act (<https://www.riigiteataja.ee/akt/13197929?leiaKehtiv>);
- Basic Schools and Upper Secondary Schools Act (<https://www.riigiteataja.ee/akt/13332410?leiaKehtiv>);
- National Curriculum for Basic Schools (<https://www.riigiteataja.ee/akt/114012011001?leiaKehtiv>) that establishes the state's basic education standard;
- National Curriculum for Upper Secondary Schools (<https://www.riigiteataja.ee/akt/114012011002?leiaKehtiv>) that establishes the state's upper secondary general education standard;
- Simplified National Curriculum for Basic Schools (<https://www.riigiteataja.ee/akt/128122010014?leiaKehtiv>).

In 2010, significant changes took place in the legal framework for general education system. On 01.09.2010, the new Basic Schools and Upper Secondary Schools Act (BSUSSA), the National Curriculum for Basic Schools (NCBS), Simplified National Curriculum for Basic Schools (SNCBS) and the National Curriculum for Upper Secondary Schools (NCUSS) entered into force. Amendments to the BSUCCA adopted in 2011 and 2013 did not introduce any changes into the general education qualifications.

A three-year transition period (2010-2013) has been provided to implement the new national curricula. During this period the National Curriculum for Basic and Upper Secondary Schools that entered into force in 2002 remained valid and the new curricula gradually enter into force. The basis of referencing the general education qualifications to the EstQF (see Clause 3.1.3) were LOs, described in the new national curricula. Taking into consideration that no fundamental changes were planned with the implementation of the new national curricula, the conclusions may be considered to apply for the year 2002 national curriculum, as well.

According to the Education Act, nine-year basic education is the minimum level of compulsory general education, the acquisition of which provides the prerequisites and grants the right to continue studies to acquire upper secondary education.

The purpose of basic school is to ensure student's age-appropriate cognitive, moral, physical and social development and formation of an integral view of the world, and to create an age-appropriate, safe, positive and stimulating learning environment. The purpose of upper secondary school is to ensure that

students find an area of activity suitable for their interests and capabilities, to which they would like to tie their future education or work activities (at an institution of higher education or VET institution).

The SNCBS includes two national curricula:

- simplified national curriculum for basic schools;
- curriculum for students with moderate and severe learning disabilities.

On the basis of the SNCBS, studies of students directed to supplementary studies or students with moderate and serious mental disabilities take place.

The NCBS is further divided into three stages of study: the first stage involves grades 1–3, the second stage 4–6 and the third, 7–9. The upper secondary school curriculum corresponds to the fourth stage of general education. The NCBC and NCUSS describe LOs for each stage of study.

The acquisition of upper secondary general education provides the prerequisites for and grants the right to continuing studies to acquire higher education or vocational education based on upper secondary education.

According to the BSUSSA, it is possible to conduct studies in Estonia by following the curriculum formulated under the aegis of either the International Baccalaureate Organisation (IBO) or the Statute of the European Schools. These curricula are designed foremost for the children of the foreign officials and specialists working in Estonia.

3.1.2 Qualification framework of general education

There are **two qualifications** in the Estonian general education system:

- **basic education certificate;**
- **upper secondary general education certificate.**

Basic education certificates shall contain a notation of under which curriculum (NCBS or SNCBS) the basic school was graduated, because there are significant differences in the level of LOs of different curricula. Therefore, there are two qualifications in addition to basic education certificate:

- **basic education certificate based on simplified curriculum;**
- **basic education certificate based on curriculum for students with moderate and severe learning disabilities.**

LOs of the above four qualifications are presented in Table 3.1.

Table 3.1. Learning outcomes of general education qualifications

Graduate of curriculum for students with moderate and severe learning disabilities	Graduate of simplified curriculum for basic school	Graduate of basic education curriculum	Graduate of upper secondary school curriculum
Characterizes and compares objects/regions using different sources of information, gives examples of links	Adequately communicates in everyday situations (listens to partner, asks questions, explains his positions, solves	Is familiar with generally recognised values and moral norms, follows them, does not remain indifferent when they are disregarded, and shall interfere within his or	Conducts in an ethical manner, follows the generally accepted values and moral norms;

<p>between natural elements, between environment and human activities, provides information to fellow students; Distinguishes and names human organs based on a model/drawing and describes their functions; Knows and values the principles of a healthy lifestyle; Demonstrates basic first aid techniques in a learning situation; Describes and explains characteristics of learned phenomena and gives examples of their occurrence in everyday life; Describes the operation principles of simple household equipment, safely handles everyday household instrumentation; Gives examples of the usage of learned substances/materials in everyday life, understands the dangers of known chemicals and follows necessary safety requirements; Gives examples of the usage of electrical appliances in daily life, explains their purpose and safety requirements; Understands the principles for environment sustainability, describes environment saving methods;</p>	<p>differences, admits his errors and misconduct); responds adequately to misbehaviour towards himself and others; Assesses the behaviour of himself and his peers in everyday situations in accordance to society norms, behaves accordingly; Knows the rules and norms of supportive relationships between humans, values compassion, honesty, justice and responsibility; Describes the conditions for the development of infants and toddlers and care methods; Understands the importance of basic human resources (time, knowledge /skills, work, money), is able to plan the activities relating to the replenishment/ consuming of these resources; Is able to request information from others, use informational texts and manuals; Describes housing acquisition, refurbishing and maintenance needs, opportunities, risks and liabilities; Adequately assesses his abilities, knowledge, skills, continuing education opportunities and conditions with guidance from a</p>	<p>her capabilities, when necessary; Knows and respects his or her mother tongue and culture and contributes to perseverance and development of the Estonian language and culture. Has an understanding and knowledge of different cultures of the world, regards people of other nations without prejudice and with respect; Is inquisitive, knows how to learn and find ways for further studies, using relevant advice, if necessary; Has initiative, believes in himself or herself, shapes his or her ideals, sets goals and works to achieve them, directs and corrects his or her behaviour and takes responsibility for his or her actions; Is able to express himself or herself clearly and adequately in speech and writing, regarding the situation and surrounding people; to understand and interpret different texts; knows and follows the rules of orthography; Speaks at least one foreign language at a level that enables to communicate in everyday situations in written and oral form, and to read and understand foreign texts fit for his or her age; Is able to solve issues arising in different spheres of everyday life that require the use of mathematical</p>	<p>Takes responsibility for his or her choices and obligations taken, respects other people's and one's own freedom, is a sovereign personality; Uses different learning strategies, is able to compile a research and to present it, is able to work in a team and make a contribution to achieving collective goals; Knowingly helps to preserve and develop the Estonian language, culture and country; understands the Estonian culture in the context of European and other cultures; understands, values and respects his or her cultural traditions, as well as the ones of other nations; Is able to evaluate his or her aspirations while taking into consideration his or her abilities and possibilities; is able to foresee possible success and failure; is aware of different fields of work and directions of the labour market; is able to obtain information on further studies and job opportunities; plans his or her career; Uses language correctly and expressively, is able to debate in a reasoned manner; Thinks critically and creatively, develops and values his/her ideas and the ones of others, can justify his or her choices and views; Can speak at least two foreign languages at the level of an independent language user; Uses mathematical knowledge and methods in different spheres of life; Has a developed scientific view of the world and</p>
------------------------------------------------------------------------------------------------------------------------------------------------------------------------------------------------------------------------------------------------------------------------------------------------------------------------------------------------------------------------------------------------------------------------------------------------------------------------------------------------------------------------------------------------------------------------------------------------------------------------------------------------------------------------------------------------------------------------------------------------------------------------------------------------------------------------------------------------------------------------------------------------------------------------------------------------------------------------------	----------------------------------------------------------------------------------------------------------------------------------------------------------------------------------------------------------------------------------------------------------------------------------------------------------------------------------------------------------------------------------------------------------------------------------------------------------------------------------------------------------------------------------------------------------------------------------------------------------------------------------------------------------------------------------------------------------------------------------------------------------------------------------------------------------------------------------------------------------------------------------------------------------------------------------------------------------------------------------------	-----------------------------------------------------------------------------------------------------------------------------------------------------------------------------------------------------------------------------------------------------------------------------------------------------------------------------------------------------------------------------------------------------------------------------------------------------------------------------------------------------------------------------------------------------------------------------------------------------------------------------------------------------------------------------------------------------------------------------------------------------------------------------------------------------------------------------------------------------------------------------------------------------------------------------------------------------------------------------------------------------------------------------------------------------------------------------------------------------------------------------------------------------------------------------------------------	--------------------------------------------------------------------------------------------------------------------------------------------------------------------------------------------------------------------------------------------------------------------------------------------------------------------------------------------------------------------------------------------------------------------------------------------------------------------------------------------------------------------------------------------------------------------------------------------------------------------------------------------------------------------------------------------------------------------------------------------------------------------------------------------------------------------------------------------------------------------------------------------------------------------------------------------------------------------------------------------------------------------------------------------------------------------------------------------------------------------------------------------------------------------------------------------------------------------------------------------------------------------------------------------------------------------------------------------------------------------------------------------

	<p>counsellor and makes the most appropriate career choice; Knows his basic rights and obligations as an employee, can name ways to obtain help and information on issues related to labour law; Understands the risks and negative consequences of working without a contract and envelope salary;</p> <p>Recognises signs of human trafficking on job search, is aware of the risks and can describe the correct behaviour when falling to victim of human trafficking;</p>	<p>methods (equations, models, schemes, graphs);</p> <p>Understands the connections between humans and environment, is responsible towards the living environment and lives and acts in a way that saves nature and the environment;</p> <p>Knows how to ask questions of natural science, have a discussion on them, present scientific views and make deductions based on evidence;</p> <p>Is able to manage in the world of technology and to use technology purposefully and with as little risk as possible;</p> <p>Is an active and responsible citizen who is interested in the democratic development of his or her school, community and country;</p> <p>Is able to express himself or herself creatively, respects art and cultural heritage;</p> <p>Values and practices a healthy lifestyle and is physically active;</p> <p>Thinks systematically, creatively and critically, is open to self-development</p>	<p>understands the essence of modern natural sciences; is familiar with global issues and takes personal responsibility for helping to solve them; values and follows the principles of sustainable development;</p> <p>Uses modern technology purposefully and with a sense of responsibility, values the impact of technology on everyday life, has conscious views on development of technology and its use;</p> <p>Has developed and active position as a citizen, sees himself or herself as a dialogue competent member of society in the contexts of Estonia, Europe and the world; is able to avoid and solve conflicts, is tolerant;</p> <p>Appreciates fine arts, is able to use tools in his or her creations, as well as techniques and materials;</p> <p>Practices a healthy lifestyle, knows how to preserve and restore his or her mental and physical health.</p>
--	---------------------------------------------------------------------------------------------------------------------------------------------------------------------------------------------------------------------------------------------------------------------------------------------------------------------------------------------------------------------------------------------------------------------------------------------------------------------------------------	----------------------------------------------------------------------------------------------------------------------------------------------------------------------------------------------------------------------------------------------------------------------------------------------------------------------------------------------------------------------------------------------------------------------------------------------------------------------------------------------------------------------------------------------------------------------------------------------------------------------------------------------------------------------------------------------------------------------------------------------------------------------------------------------------------------------------------------------------------------------------------------------------------------------------	-----------------------------------------------------------------------------------------------------------------------------------------------------------------------------------------------------------------------------------------------------------------------------------------------------------------------------------------------------------------------------------------------------------------------------------------------------------------------------------------------------------------------------------------------------------------------------------------------------------------------------------------------------------------------------------------------------------------------------------------------------------------------------------------------------------------------------------------------------------------------------------

3.1.3. Referencing general education qualifications to the EstQF

Since the qualifications of general education were not assigned the EstQF levels during the development of the national curricula in 2009-2010, the following analysis has been prepared upon the approval of these curricula. The results of the analysis were used to assign general education qualifications the EstQF levels.

Basic education certificate

LOs of a graduate from basic school curriculum are presented in Table 3.1. Attitudes, values, and behaviour based on these LOs have an important role in the basic school curriculum.

The LOs of basic school graduate are described on the level of grade “Good”, which means that a performance lower than that may still be considered satisfactory. The link between the level of LOs and assessment is not clearly fixed at the moment, although the corresponding assessment framework has been approved by the regulation of the MoER (<https://www.riigiteataja.ee/akt/131052012011?leiaKehtiv>).

Comparison between the LOs of the EstQF level 2 and at the end of basic school

The “basic factual knowledge of a field of work or study” described in the EstQF have been represented in the following LOs or parts thereof:

- has knowledge of different cultures of the world;
- knows the rules of orthography of ...;
- speaks at least one foreign language at a level that enables him or her to communicate in everyday situations in written and oral form, and to read and understand foreign texts fit for his or her age.

The “basic cognitive and practical skills required to use relevant information in order to carry out tasks and to solve routine problems using simple rules and tools” and “work or study under supervision with some autonomy” described in EstQF can be recognised in the following LOs:

- is inquisitive, knows how to learn and find ways for further studies, using relevant advice if necessary;
- is initiative, believes in himself or herself, sets goals and works to achieve them, directs and corrects his or her behaviour and takes responsibility for his or her actions;
- is able to solve issues arising in different spheres of everyday life that require the use of mathematical methods of thought (logic and spatial thinking) and ways of presentation;
- understands the connections between humans and the environment;
- knows how to ask questions on natural science, discuss them, present scientific views and make conclusions based on evidence;
- is able to manage in the world of technology and to use technology purposefully;
- is able to express oneself creatively;
- thinks systematically, creatively and critically.

The LOs of the NCBS do not refer to any factual or theoretical knowledge that is emphasized in the knowledge descriptor of the EstQF. The facts and theory are presented in the LOs through the prism of cognitive and practical skills. The reason for that is a pedagogical view that unrelated facts do not have substantial significance in the long run. Characteristically to a small nation, foreign language skills hold an important role in the NCBS LOs, which is also not mentioned separately in the EstQF.

In analysing the qualitative differences, the level of the learner’s autonomy in the LOs described in the NCBS is considerably larger, referring only once to the need of using relevant advice. At the same time, it may be stated in the case of drawing conclusions about managing in the world of technology and deduction based on evidence that it is done under someone’s instructions. The LOs on analytical and deduction skills refers to more than “using simple rules and tools”. Also, the LOs that presumes a person’s ability to solve different issues arising from different spheres of everyday life is more demanding than the EstQF level description.

As to analysing cognitive skills, the role of logic has been emphasised several times in the NCBSLO, as well as creativity and self-expression. However, there is no reference to intuition, which is one of the aspects of the EstQF cognitive skills. However, there are several references to practical skills, and, in a more indirect manner, to problem-solving.

Since the LOs at the end of basic school are higher at several points than the EstQF level 2 LOs, they have been compared to the EstQF level 3 hereinafter.

Comparison between the LOs of the EstQF level 3 and at the end of basic school

When comparing LOs at the end of NCBS to the EstQF level 3, the following links can be found. “Knowledge of facts, principles, processes and general concepts in a field of work or study” are reflected in the following descriptions of the LOs at the end of basic school: “understands the connections between humans and the environment”, “can ask questions on natural science, have a discussion on them, present scientific views and make deductions based on evidence”, “is able to manage in the world of technology and use technology purposefully and with as little risk as possible”, “has an understanding and knowledge of different cultures of the world”, etc. As it was already mentioned above, acquisition of factual or theoretical knowledge is not a separate goal in Estonia, therefore they can be analysed mostly through the cognitive processes.

The aforementioned examples refer to the description of cognitive and practical skills on the EstQF level 3, presuming, among other things, an ability to accomplish tasks and solve problems “by selecting and applying basic methods, tools, materials and information”. Purposeful use of technology, an ability to learn, an ability to express oneself adequately while taking into account the conversation partners, solving everyday issues through mathematical methods and all other similar LOs clearly refer to acquisition of relatively broad skills.

Autonomy and responsibility that correspond to the EstQF level 3 description “takes responsibility for completion of tasks in work or study; adapts one’s behaviour to particular circumstances in solving problems” can be found in the following LO: “has initiative, sets goals and works towards achieving them, directs and corrects his or her behaviour and takes responsibility for his or her actions”.

To conclude, there is a relatively large similarity between the EstQF level 3 descriptions and the expected LOs at the end of basic school. Considering that the NCBS describes the expected LOs at the grade level of “Good”, a basic school certificate should nevertheless be considered as an EstQF level 2 qualification.

Comparison between the LOs of the EstQF level 2 and at the end of basic school according to the 2002 national curriculum

Similarly to the NCBS, the LOs described in the national curriculum of 2002 are considerably more diverse and demanding than the EQF level 2 descriptions. It is understandable, considering that the 2002 national curriculum describes the learning and educational objectives of basic schools as an ideal, that is, at the grade level of “Excellent”. However, the relation of a grade to the achieved LOs has not been determined explicitly. Therefore, it is logical that when reduced to the base level, the LOs of the 2002 national curriculum could also correspond to the EstQF level 2.

To conclude, it may be said that the expected LOs at the end of basic school described in the NCBS have a significantly higher level on several points than is presumed in the description of the EstQF level 2. However, when we take into consideration that the LOs have been described at the grade level “Good”, which cannot be fixed very precisely and is certainly not achieved by all students who graduate from basic school, the **basic school certificate may be assigned the EstQF level 2.**

Basic education certificate based on simplified curriculum and curriculum for students with moderate and severe learning disabilities

The content of simplified curriculum for basic school is mostly aimed at acquisition of practical skills and knowledge. The curriculum has been compiled in a way that enables students to acquire the knowledge,

skills and values that enable them to manage in their everyday life. The curriculum aims to support learning through practice. The purpose of rules and theories is to generalise and make the students aware of the knowledge acquired through practice. The practical skills are formulated more precisely in the subject syllabi. Making students more active means that there has to be a selection of activities corresponding to their physical development, accomplishable learning activities, clear and understandable setting of objectives, constant stimulation of students' activity and evaluation of the improvements made. The curriculum emphasises the importance of an emotional connection between an educational specialist and students in joint activities, as well as the importance of learning environment.

In the simplified curriculum more attention has been given to crafts, and less to natural sciences (physics, chemistry) and foreign languages. The curriculum also has a separate subject of life and surroundings studies. The **SNCBSs' LOs can be** considered compatible to the EstQF level 2 and the corresponding qualification **referenced to the EstQF level 2.**

The curriculum for students with moderate and severe learning disabilities enables the acquisition of basic education that corresponds to the student's abilities and level of development. The main purpose of training for students with moderate and severe learning disabilities is to support students' development by corrective work, to shape a person who is able to manage everyday activities at home and in service providing institutions, and is able to carry out simpler tasks under direct supervision and guidance. The aim of teaching is to shape psychophysiological compensation mechanisms, develop the realm of emotions and will, support the development in a student's self-reliance and his or her motor, cognitive, communicative and social skills, and therefore improve his or her coping in society. If necessary, a student can extend his or her time for study by three years.

When comparing the EstQF level 1 description to the descriptions of the curriculum LOs, they can be considered similar in certain cases. For example, students may have "the basic skills required to carry out simple tasks" and they may be capable to "work or study under direct supervision in a structured content". Using the principle of best fit, it can be said that the **LOs of the students graduating from the curriculum for students with moderate and severe learning disabilities are compatible to the EstQF level 1.**

Upper secondary education certificate

The LOs at the end of upper secondary school have been described in the NCUSS similarly to the ones of basic school and are presented in Table 3.1. Unlike in the NCBS, the LOs at the end of upper secondary school are described on the grade level "Satisfactory".

Comparison between the LOs of the EstQF level 4 and at the end of upper secondary school

When comparing the EstQF level 4 descriptors with LOs at the end of upper secondary school, several similarities with the NCBS can be found. The NCUSS pays a lot of attention to the description of attitudes and behaviour based on thereof, including as to preserving our national culture and respecting cultural traditions of other nations. Similarly, foreign language learning has an important role, whereas a person graduating from upper secondary school is expected to know at least two foreign languages at the level of an independent language user. There are clear suggestions to cognitive skills relating to logic and creativity in the NCUSS LOs, but there are no references to using one's intuition.

Since it is a generalised list of LOs, there are not many direct references to facts and theories, similarly to the NCBS. However, some expressions can be found, for example "is aware of different fields of work and tendencies on the labour market" or "is aware of the global problems". However, the knowledge is mostly presented through a prism of cognitive and practical skills that may be considered pedagogically successful. The LOs also have a wide scope. Among others, this is expressed by the phrases "understands

the Estonian culture in the context of the cultures of other nations”, “uses mathematical knowledge and methods in different spheres of life” or “sees himself or herself as a dialogue competent member of society in the contexts of Estonia, Europe and the world”.

Several LOs can be listed under cognitive and practical skills: “uses different learning strategies, is able to compile a research and to present it, is able to work in a team and make a contribution to achieving collective goals”, “uses mathematical knowledge and methods in different spheres of life”, “uses modern technology purposefully and with a sense of responsibility” and “is able to use tools in his or her creations, as well as techniques and materials”.

The following parts of the LOs go well with the autonomy and responsibility definitions of the EstQF level 4: “takes responsibility for his or her choices and obligations taken”, “is able to obtain information on further studies and job opportunities, plans his or her career” or “knows how to preserve and restore his or her mental and physical health”. In addition to these, the following phrases match the EstQF level 4 description: “supervises the routine work of others, taking some responsibility for the evaluation and improvement of work or study activities” and several other formulations in the LOs at the end of upper secondary school, including the ones that refer to being a member of a team and contributing to achieving the common goal.

The LOs stated in the NCUSS generally correspond to the descriptions of the EstQF level 4. However, one important difference relates to the supervision of the routine work of others. If we regard working as making a contribution to common goals, it does not exclude supervision of others.

Due to vague formulation, there is no direct reference to “generating solutions to specific problems” in the upper secondary school LOs, but there are formulations like “is able to debate in a reasoned manner”, “can justify his or her choices and views” and “is able to avoid and solve conflicts”. Instead of solving specific problems, the upper secondary school LOs include a clear reference to global issues for which a student graduating from the upper secondary school is expected to take some responsibility. This is far more than is expected in the EstQF level 4. The EstQF has no references on being a citizen – whether in one’s own country or in the world.

To conclude, the **upper secondary level LOs are compatible with the EstQF level 4**. It may even be said that due to its versatility, the NCUSS LOs exceed the EstQF level 4 descriptors.

On the basis of the aforementioned analysis, it is suggested to reference the general education qualifications to the EstQF in the following way:

EstQF level	General educational qualification	Comments
Level 1	Basic education certificate based on curriculum for students with moderate and severe learning disabilities	
Level 2	Basic education certificate Basic education certificate based on simplified curriculum	Learning outcomes are described on grade level “Good”
Level 4	Upper secondary education certificate	Learning outcomes are described on grade level

3.1.4. Institutions awarding the qualification of general education and graduation requirements

Schools in Estonia operate on the basis of licence issued by the MoER. A licence gives a school the right to offer study programme at the corresponding level of general education and to issue nationally recognised graduation certificates, i.e. to act as a qualification awarding institution.

According to the NCBS, in order to graduate from basic school, a student has to pass unified basic school final examinations, or in the cases stated in the NCBS (special needs and individual curriculum), school exams in the following subjects: Estonian language or Estonian as a second language (for students whose language of instruction has been Russian), mathematics and one optional examination from the subjects allowed by the MoER on the choice of the student.

In order to graduate from upper secondary school, a student has to:

- 1) pass national examinations in Estonian or Estonian as a second language (for students whose language of instruction has been Russian), mathematics and foreign language;
- 2) pass an upper secondary school examination involving subject or subjects based on the school's field of study, social studies and nature;
- 3) complete a research or a practical work (except when graduating as an extern).

In order to graduate from upper secondary school at least satisfactory national examination results are needed (more than 50% of correct answers).

3.1.5. General education qualification certificates

The forms of graduation certificates and certificate supplements, the statute and the procedure for issuing thereof has been laid down by the Government of the Republic regulation the Form, Statute and Procedure for Issue of the Graduation Certificate from a Basic School and Upper Secondary School (<https://www.riigiteataja.ee/akt/13349551?leiaKehtiv>). School graduation certificate is a national document that is issued by a basic school or an upper secondary school to a person who has completed his or her studies by fully completing the curriculum. Certificates are printed on a special graduation certificate form that has security features.

Basic education certificate is issued to a person who has completed the national basic school curriculum or a basic education based on a simplified curriculum, or curriculum for students with moderate and severe learning disabilities, and passed the basic school final examinations. Upper secondary education certificate is issued to a person who has completed the national upper secondary school curriculum and passed the upper secondary school final examinations.

School graduation certificates are printed on a special graduation certificate form that has security features. A graduation certificate is issued by the school which the student attended. A certificate supplement shall be issued as an annex to a graduation certificate. It gives information about the curriculum and on the results of its completion. A certificate supplement shows the final grades of compulsory and elective subjects in numerical or letter format, as well as the subjects and grades of the basic school final examinations. School graduation certificates are issued on the basis of a decision of the school's learning council. The data regarding graduation certificates of basic school and upper secondary schools are entered into the sub-register of qualifications certificates of the Estonian Education Information System (hereinafter EHIS).

Since May 2014 institutions awarding general education qualifications are adding a reference to the corresponding EQF and EstQF level to the issued qualification certificates <https://www.riigiteataja.ee/en/eli/513012014002/consolide/current>.

3.1.6. Recognition of prior learning in general education

Recognition of prior learning (RPL) in general education mostly means recognising previous or simultaneous studies somewhere else, whether it is abroad, in hobby groups and sports schools, or acquired on one's own. The NCBS enables such recognition when the student's parent and school's representative (a headmaster or an authorised educational specialist) reach an agreement thereof and when it enables the acquisition of LOs determined by the school or the student's individual curriculum. The student's opinion is not asked in this

case, although the NCBS LOs expect quite a significant level of independence from students in making their life decisions.

The BSUSSA states that a local government has to ensure the possibility of acquiring basic education for persons 17 years of age or older that have not acquired basic education. It enables people to continue previously interrupted studies. Upon the decision of the school's headmaster, additional learning may be offered in basic schools to people who have graduated from basic school under the simplified curriculum with an aim to offer further preparation and support for smoother continuation of studies or entering the labour market. In the case of adult students, certifying knowledge and skills through RPL is also allowed as a part of summative evaluation.

The NCUSS allows certifying knowledge and skills through RPL without exceptions for all students.

3.1.7. Quality assurance in general education

The quality assurance in the Estonian general education system is made up of:

- internal quality assurance at schools together with corresponding external consultations;
- periodical external evaluation of schools (national standardised tests, national examinations and incident-based national supervision).

National curricula and school curricula based on expected LOs create better opportunities for quality assessment and quality assurance.

Since 1997 the National Examinations and Qualifications Centre (NEQC) has carried out national standardised tests, basic school final examinations, and national school leaving examinations for upper secondary schools. In 2012 the NEQC became a structural unit of the Foundation Innove (General Education and Monitoring Agency http://www.innove.ee/UserFiles/Organisatsioonist/struktuur2015_eng1.pdf). The level of students' achievement is evaluated at a national level at the end of each 3-year stage of study. The national standardised tests of the first three study stages are graded centrally on the basis of random selection. All of the national school leaving examinations for upper secondary school are graded centrally.

Formulating the LOs by stages of study enables the selection of key aspects from the subject volume and focusing on these. This enables to improve the comparability of national standardised tests and examinations from different years.

3.2. Sub-framework of VET qualifications

3.2.1. Legal framework of VET

In 2013, the parliament passed the VET Act (<https://www.riigiteataja.ee/en/eli/505022014002/consolide>) that substantially transformed the regulation of the VET system:

- defining new levels of VET qualifications linked to the EstQF;
- extensive use of LOs based approach;
- establishing the new quality assurance structure for VET;
- defining the Estonian VET Credit Points for measuring study volumes.

The VET Institutions Act that establishes the levels of VET qualifications, principles of formulating the Standard of VET (SVET) and national curricula for VET, the bases for establishment, reorganisation and closure of VET institutions; the principles of VET institutions management, the bases for their budgeting and financing, the rights and obligations of VET institutions personnel, internal evaluation and state supervision over the activities of schools.

Uniform requirements for VET curricula and qualifications are regulated by the Standard of VET (SVET) (<https://www.riigiteataja.ee/akt/128082013013>). The SVET laid down by the regulation of the Government of the Republic is a collection of uniform requirements for VET programmes and qualifications. The standard describes the requirements for national and school curricula, determines the terms and conditions for RPL, describes the objectives, expected LOs, volumes of study and graduation requirements for different levels of initial and continuous VET programmes, requirements for pedagogical professionals, and the curriculum groups in accordance with the ISCED 97 classification. It also assigns the EstQF levels to the VET qualifications.

The national curricula for VET (<http://www.innove.ee/et/kutseharidus/kutsehariduse-rok>), developed for the upper secondary VET qualifications, are entered into force by regulations of the MoER. By September 2016, 20 national curricula for VET have been approved.

In order to speed up the implementation of reforms instigated by the VET Institutions Act and the new Standard for VET, a reform of the vocational education curricula and management was launched in September 2013. As a result, VET institutions have implemented more than 600 LOs based new curricula. New upper secondary VET curricula have been developed and implemented in some study programme groups where so far only post-secondary programmes were offered. New upper secondary VET curricula integrate the development of key competences and professional competences.

3.2.2. VET qualifications

The VET Institutions Act stipulates five VET qualifications:

- **VET qualification certificate, level 2,**
- **VET qualification certificate, level 3,**
- **VET qualification certificate, level 4,**
- **Upper secondary VET certificate (referenced to the EstQF level 4),**
- **VET qualification certificate, level 5.**

Figure 3.1 presents correspondence between the VET qualifications effective till 01.09.2013 and the new VET qualifications. Table 3.2 describes the new types of VET curricula.

3.2.3. VET standards

There are two national VET standards in Estonia:

- the Standard of VET (SVET);

- national curricula for VET.

The SVET includes LOs of VET qualification levels and their relation to the EstQF, curricula and training requirements and tasks, the principles of modifying curricula, the principles of RPL, and the lists of fields of study and curriculum groups.

VET qualifications till 01.09.2013	EstQF level	VET qualifications since 01.09.2013
VET without basic education requirement certificate	2	VET qualification certificate, level 2
VET based on basic education certificate	3	VET qualification certificate, level 3
Upper secondary VET certificate VET based on upper secondary education certificate	4	Upper secondary VET certificate VET qualification certificate, level 4
	5	VET qualification certificate, level 5

Figure 3.1. Correspondence between the VET qualifications effective till 01.09.2013 and the new VET qualifications

The SVET describes the LOs of qualification levels at the threshold level needed to complete a programme or a module (at the level of the grade "3"). The SVET describes the following competences as the LOs by level:

- Occupation specific knowledge;
- Occupation specific skills, autonomy and responsibility;
- Learning competence;
- Communication competence;
- Self-definition competence;
- Operational competence;
- IT-competence;
- Entrepreneurship competence.

The content of VET is based on occupational qualification standards, in their absence on an input from social partners, on key competences for lifelong learning stipulated in the Recommendation of the European Parliament and the Council from 18 December 2006. Additionally, the content of upper secondary VET is based on the NCUSS.

National curriculum of VET is the basic document for the development of school curricula in upper secondary VET. The national curriculum shall be compiled in cooperation with social partners and is based on the SVET, relevant occupational qualification standards and the NCUSS.

The basic document for studies is the school curriculum. The school curricula are divided into the initial and continuous VET curricula. Both, initial and continuous VET curricula can be compiled as joint curricula. The school compiles a curriculum for a certain level of the EstQF for every study programme offered by the school. If a curriculum offers possibility to acquire several qualifications or partial qualifications, the required modules with their learning outcomes shall be determined.

Table 3.2. Types of VET curricula and qualifications for the EstQF levels 2-5 as of 01.09.2013

	Types of VET qualifications						
	Level 2 Basic training	Level 3 Basic training	Level 4			Level 5	
			Basic training		Continuous training	Basic training	Continuous training
Educational requirements for commencing studies	none	none	Vocational secondary education Basic education * Persons without basic education and at least 22 years of age	Basic education	Basic education plus competences required for level 4 qualifications	Secondary education	Upper secondary education plus the competences required for level 4 or 5 qualifications
Study volume in EstVETCP	15-120	15-120	180 <i>Exceptions expanding the study volumes will be stipulated in national curricula</i>	15-150 <i>Music and performance art curricula up to 180</i>	15-60	120-150 <i>Military and internal security curricula ranging between 60-150</i>	15-60
Ratio of practical assignments	at least 70%	at least 50%	at least 35%	at least 50%	at least 50%	at least 50%	at least 50%
Opportunities for further study	Obtaining basic education * If basic education has been acquired, general secondary education or vocational secondary education or entry level 4 vocational training * Persons without basic education and at least 22 years of age Vocational secondary education * Level 3 vocational training	Obtaining basic education * If basic education has been acquired, general secondary education or vocational secondary education or entry level 4 vocational training * Persons without basic education and at least 22 years of age Vocational secondary education	Level 4 or 5 vocational education continuing training * General education studies lasting 1 year * Vocational higher education or bachelors studies	Level 4 vocational education continuing training * General or vocational secondary education * If secondary education has been acquired – level 5 vocational training or vocational higher education or bachelor studies	General or vocational secondary education * If secondary education has been acquired – level 5 vocational training or vocational higher education or bachelor studies	Level 5 vocational education continuing training * Vocational higher education or bachelors studies	Vocational higher education or bachelors studies
Corresponding labour market requirement	Manual labourers	Simpler professions involving operating machines and devices, less complex skilled labourers, craftsmen and sales/service personnel	More demanding tasks involving machines and devices, craftsmanship and skilled labour, skilled labourers in the fields of agriculture and fishing, service and administration			Intermediate level specialists, technicians and officials	Complex tasks involving machines and devices, craftsmanship and skilled labour, highly skilled labourers in the fields of agriculture and fishing, service and administration

Curriculum consists of modules. A module is an integral content unit containing the description of learning outcomes matching the competence requirements of the occupational qualification standard. The volume of the module in credit points depends on the purpose of the module and learning outcomes. The modules are divided into basic study, elective study and general study modules.

Classification of curricula into broad groups of studies, fields of study and programmes is based on the ISCED 97.

3.2.4. Assigning the EstQF level to VET qualifications

Learning outcomes of the second level VET qualification

The graduate of the second level VET curriculum has achieved the following learning outcomes:

Occupation specific knowledge:

- knows and describes the main concepts and principles of the occupation;
- understands the main work processes, is familiar with the occupation specific terms, materials, tools and with commonly used equipment.

Occupation specific skills, autonomy and responsibility:

- is able to fulfil simple occupation specific tasks with limited responsibility;
- is able to perform the job tasks under the guidance;
- is working efficiently in stable work situations.

Learning competence:

- is able to learn upon guidance and counselling.

Communication competence:

- is able to communicate in common situations and with familiar partners;
- is able to use advice, help, support and provided information materials to solve occupation specific issues.

Self-definition competence:

- is able to evaluate the results of work upon counselling.

Operational competence:

- is able to adapt and cope in different social environments upon guidance.

IT competence:

- has some knowledge about the possibilities offered by IT;
- is able to use internet to certain extent;
- is able to use some applications upon guidance.

Entrepreneurship competence:

- is able to express the ideas and apply them upon guidance;
- is able to make appropriate choices under guidance from provided opportunities, that are suitable to his/her skills;
- takes part in his/her career planning.

Learning outcomes of the third level VET qualifications

The graduate of the third level VET curriculum has achieved the following learning outcomes:

Occupation specific knowledge:

- knows occupation specific terminology, principles, technologies, processes, techniques, materials, tools, equipment, and is able to use and apply them.

Occupation specific skills, autonomy and responsibility:

- is able to independently fulfil various occupation specific assignments;

- is able to work independently and be responsible of the work results in stable or in slightly variable situations;
- is responsible for his/her job performance.

Learning competence:

- is able to learn and self-develop independently.

Communication competence:

- is able to substantiate his/her opinions and express him/herself in various situations both orally and in writing;
- is able to use common sources of information to solve occupation specific issues.

Self-definition competence:

- is able to solve occupation specific issues in an optimal way and change his/her behaviour if necessary.

Operational competence:

- is participating effectively in different teams and is able to fulfil various roles within these teams.

IT competence:

- knows the main possibilities and potential threats of IT;
- is able to use the main possibilities available on the internet both for personal and occupational purposes.

Entrepreneurship competence:

- is able to use various resources and means to develop ideas and to implement them;
- is able to express opinions about experiences, describe, present and evaluate his/her ideas and work;
- is able to set career goals upon guidance;
- is able to find information (incl. using electronic channels) about job vacancies upon guidance;
- is able to associate the requirements of occupation specific training with the employability on the labour market upon guidance.

Learning outcomes of the fourth level VET qualification

The graduate of the fourth level VET curriculum has achieved the following learning outcomes:

Occupation specific knowledge:

- has in-depth knowledge of the occupation, incl. knowledge how to implement principles, theories and technologies of the vocation both in common and new work situations.

Occupation specific skills, autonomy and responsibility:

- is able to independently fulfil complex and variable assignments of the occupation that require innovative solutions;
- is responsible for fulfilling his/her work assignments.

Learning competence:

- uses initiative to learn and self-develop independently!
- is able to evaluate and analyse his/her level of knowledge.

Communication competence:

- is able to substantiate his/her opinions in detail and express them also in new situations both orally and in writing;
- is able to use specific sources of information to solve occupation specific issues, evaluate the reliability and validity of the information used.

Self-definition competence:

- is able to use self-evaluation to change his/her behaviour;
- is able to make suggestions to improve the work results.

Operational competence:

- is able to participate effectively in various teams and lead them if necessary;
- is partially able to guide co-workers.

IT-competence:

- knows the role, possibilities and potential threats of IT;
- is able to critically evaluate the reliability of available information;
- is able to use the main application programmes and possibilities of the internet both for personal and occupational purposes;
- is able to create, present and understand information using software tools and use internet-based search systems and other services.

Entrepreneurship competence:

- is able to think systematically and creatively, critically evaluate and find possibilities to implement his/her ideas;
- is able to initiate, develop and implement ideas;
- has primary knowledge about entrepreneurship;
- is able to compile his/her short- and long-term career plan upon guidance;
- is able to independently find opportunities for occupation specific self-development and its application on the labour market;
- is able to associate the requirements of occupation specific training with the employability on the labour market.

Learning outcomes of the upper secondary VET qualifications

The graduates of the upper secondary VET curriculum have achieved the following learning outcomes, with the respective competences being developed throughout the whole curriculum:

Occupation specific knowledge:

- as in-depth knowledge of his/her occupation, including knowledge how to implement occupation specific principles, theories, technologies both in common and new worksituations;
- associates occupation specific knowledge with scientific methods and with the basic principles and processes of natural sciences and mathematics;
- understands the development of scientific theories, applications and technologies and the associated risks, values security and sustainable development.

Occupation specific skills, autonomy and responsibility:

- is able to independently fulfil complex and variable occupation specific assignments requiring innovative solutions;
- is responsible for fulfilling his/her work assignments;
- is able to use mathematical knowledge and methods in different life situations;
- is able to express him/herself, present and substantiate his/her opinions both orally and in writing in a native language and in a foreign language on a level of independent language user, taking into consideration the communication situations and partners.

Learning competence:

- uses initiative to learn and self-develop independently;
- is able to evaluate and analyse his/her level of knowledge and skills, where necessary seeks for advice, information and support;
- is able to use his/her knowledge, incl. learning skills and strategies in different contexts and in solving problems;
- is able to value the search for justifications and is able to evaluate their validity.

Communication competence:

- is able to substantiate his/her opinions in detail and express them in new situations both orally and in writing;
- is able to use various and specific sources of information to solve occupation specific issues, search, collect and process information and evaluate the reliability and validity of the information used;
- is able to formulate and express his/her oral and written arguments convincingly and in context.

Self-definition competence:

- is able to use self-evaluation to change his/her behaviour;
- is able to make suggestions to improve the work results;
- is able to perceive and value connectivity with his/her cultural heritage and with the cultural heritage of other nations, and with the events of modern culture.
- is able to value and enjoy the creativity and express him/herself creatively;
- values correct and expressive language;
- knows and values a healthy lifestyle, is able to maintain and if necessary, how to restore his/her mental and physical fitness.

Operational competence:

- is able to realise him/herself, act as an informed and responsible citizen and as a member of the society with the ability for dialogue, behave tolerantly;
- is able to participate effectively in different teams and lead them if necessary;
- is able to partly guide co-workers;
- is able to use technological tools and scientific data to achieve his/her objectives or to make a decision or a conclusion.

IT-competence:

- knows the role, possibilities and potential threats of the IT;
- is able to critically evaluate the reliability of the available information;
- is able to use the main software applications and possibilities of the internet both for personal and occupational purposes;
- is able to create, understand and present information in correct language using software tools, use internet-based search systems and other services.

Entrepreneurship competence:

- is able to think systematically and creatively and critically evaluate his/her own ideas and independently find possibilities to implement them;
- is able to initiate, develop and implement ideas;
- has primary knowledge about entrepreneurship;
- is able to compile his/her own short- and long-term career plan upon guidance;
- is able to independently find opportunities for occupation specific self-development and its application on the labour market;
- is able to associate the requirements of occupation specific training with the employability on the labour market.

Learning outcomes of the fifth level VET qualifications

The graduate of the fifth level VET curriculum has achieved the following learning outcomes:

Occupation specific knowledge:

- has in-depth knowledge of his/her occupation, incl. knowledge how to creatively implement occupation specific principles, theories and technologies both in common and new worksituations.

Occupation specific skills, autonomy and responsibility:

- is able to independently fulfil complex and variable work assignments of his/her occupation

- requiring creative and innovative solutions;
- is able to select and use appropriate methods for fulfil the work assignments and problem solving;
- is responsible for fulfilling his/her work assignments.

Learning competence:

- uses initiative to learn and self-develop independently, is able to evaluate his/her learning, determine the need for self-development and continuation of studies;
- is able to evaluate and analyse his/her level of knowledge.

Communication competence:

- is able to substantiate his/her opinions in detail and express them in new situations and communicate his/her thoughts and intentions clearly and understandably, both orally and in writing;
- is able to use different and specific sources of information to solve occupation specific issues;
- is able to evaluate the reliability and validity of the information used.

Self-definition competence:

- is able to use self-evaluation to change his/her behaviour, taking into consideration the social context where necessary;
- is able to adequately evaluate his/her work, make suggestions to improve the work results and guide to the co-workers in variable situations.

Operational competence:

- is able to guide co-workers and is able to be partly responsible for their training;
- is participating effectively in the work of various teams and is able to put teams together and lead them when necessary.

IT-competence:

- knows the information- and communication technologies necessary for the job;
- is able to critically evaluate the reliability and validity of the available information;
- is able to use the main software applications and possibilities of the internet both for personal and occupational purposes;
- is able to create, present and understand information using software tools, internet-based search systems and other services.

Entrepreneurship competence:

- is able to find and analyse relevant information to implement the ideas and evaluate the reliability of the source or the approach;
- is able to present and defend his/her viewpoints and ideas in personal, public and official communication, take decisions and experiment;
- is able to compile a business plan;
- is able to independently compile short and long-term career plans for him/herself;
- is able to analyse and evaluate independently his/her occupation specific training and its applicability on the labour market, and possibilities to continue studies.

3.2.5. Institutions awarding VET qualifications and graduation requirements

According to the VET Institutions Act VET institutions operate on the basis of licence that is issued by the MoER. A licence gives a school the right to develop and run study programmes in a study programme group or groups and to issue nationally recognised certificates, i.e., to act as an institution awarding qualifications. The list of study programme groups is based on ISCED 97 and presented in the SVET.

A VET institution compiles a curriculum for each study programme offered. A curriculum is based on the SVET and the corresponding occupational qualification standard(s), and in case of upper secondary VET qualification also on the corresponding national curriculum. School's curriculum determines the list of modules and subjects together with their volume and general description, possibilities and conditions of electing them, assessment methods, requirements for commencing studies and graduating from the school, including the final examination requirements.

The correspondence of school's curriculum to the SVET and the national curriculum is reviewed by the Vocational Education Agency of the Foundation Innove. The MoER shall register the endorsed curricula in the EHIS.

A VET programme is considered to be graduated if a student has completed the curriculum in the full extent, received positive results for tests, passed all the examinations, apprenticeship and final examination foreseen in the curriculum. The number and areas of examinations is determined by the school curriculum. The examinations are either oral, written, practical or combinations of all three, depending on the vocation and area of specialisation. Instead of a final examination, students can take a corresponding vocational examination upon graduation, and receive initial occupational qualification upon passing the examination (see Clause 3.4).

The persons graduating from a programme in another language of instruction shall pass a national examination in Estonian in order to graduate.

3.2.6. VET qualification certificates

The forms of graduation certificates and certificate supplements, the statute and the procedure for issuing thereof has been laid down by the Government of the Republic regulation the Form, Statute and Procedure for Issue of the Graduation Certificate from a VET Institution (<https://www.riigiteataja.ee/akt/120092013011?leiaKehtiv>). School graduation certificate is a national document that is issued by a VET institution or an institution of professional higher education offering VET programme, to a person who has completed his or her studies by fully completing the curriculum. Certificates are printed on a special graduation certificate form that has security features.

The text on the graduation certificate of upper secondary VET and other certificates of initial VET is different.

A supplement shall be issued as an annex to a graduation certificate. It gives information about the programme and on the results of its completion. A certificate supplement shows the final grades of compulsory and elective subjects in numerical or letter format, as well as the subjects and grades of the final examination. Certificates are issued on the basis of a decision of the school's learning council.

School graduation certificate is valid as a document certifying qualification also without the certificate supplement. A certificate supplement is not valid without a certificate. The data regarding graduation certificates are entered into the sub-register of qualification certificates of the EHIS.

Since September 2013 institutions awarding VET qualifications are adding a reference to the corresponding EQF and EstQF level to the issued qualification certificates (<https://www.riigiteataja.ee/akt/120092013011?leiaKehtiv>).

3.2.7. Recognition of prior learning in VET

RPL in vocational education is legally governed by the VET Institutions Act and on the terms and conditions set out in the SVET. The RPL terms and procedures are set out in a school's rules for organisation of studies. Prior learning may be taken into account:

- 1) in fulfilling the school's terms of admission;
- 2) in completing the curriculum except the final examination by considering the results of prior

- learning as a final grade of a subject or module;
- 3) in recognising an occupational qualification certificate as passing of final examination.

A VET institution is obligated to inform its students of the RPL terms, conditions and procedures, including the deadlines and expenses related to the assessment and validation, and of the possibilities of contesting the results, ensure all the necessary information to the applicants and availability of counselling.

RPL is certified by a graduation certificate, diploma or some other certifying document. Experiential learning, hobby activities or any other everyday activity shall be certified by a reference to the work accomplished and its presentation, an occupational qualification certificate, contract of employment, copy of assignment to the post or any other documental proof. A description of the vocational experience and self-analysis is added to the application.

If necessary, a school has the right to give an applicant some practical tasks, have an interview with him or her, or evaluate his or her skills in some other way in order to evaluate prior learning.

3.2.8. Quality assurance system in VET

The quality assurance in the Estonian VET system is made up of:

- internal quality assurance systems at VET institutions;
- external quality assurance of school's study programme groups.

External quality assurance of school's study programme groups is conducted in the process of **awarding the right to provide instruction**. The right to provide instruction means the right granted to a school for a specified term to provide VET in the relevant study programme group with a directive of the minister of education and research. The right to provide instruction shall be granted upon the establishment of a new school or opening a new study programme group at a school holding the right to provide instruction.

The minister of education and research shall decide the granting of the right to provide instruction on the basis of documents submitted by the school and the results of assessment by an expert committee, and additional evidence, if necessary. The right to provide instruction upon the establishment of a new school or opening study in a new curriculum group shall be granted for three years.

Upon the extension of the right to provide instruction, the performance and sustainability of study processes (teaching and learning), leadership and management, human resources management, cooperation with stakeholders and management of resources are evaluated.

In order to extend the right to provide instruction, the relevant curriculum group shall be accredited. Accreditation means the external evaluation of study programme groups at schools, based on self-evaluation reports, and assessment conducted by external evaluation committee. The conditions and procedure for accreditation are established by a regulation of the minister of education and research. Accreditation is organised by the EKKA.

The minister of education and research has nominated the **Quality Evaluation Council for VET** under the auspices of the EKKA, which approves the accreditation decision and makes a proposal on the extension of the right to provide instruction. An assessment council has thirteen members and its membership includes:

- representatives of the Ministry of Education and Research;
- six experts of different broad groups of study in which vocational education is provided and which have been specified in the SVET;
- representatives of employers' central organisations and other interested parties.

Three of the experts are appointed by the body of chairmen of sector skills councils specified and three experts by the minister of education and research.

On the proposal of the evaluation council the minister of education and research shall make one of the following decisions:

- to extend the right to provide instruction in a curriculum group by six years;
- to extend the right to provide instruction in a curriculum group by three years;
- to refuse to extend the right to provide instruction.

3.3. Sub-framework for higher education qualifications

3.3.1. Legal framework of higher education

Legal framework for higher education in Estonia is laid down in the following legal acts:

- Republic of Estonia Education Act (<https://www.riigiteataja.ee/akt/13198443?leiaKehtiv>);
- Universities Act (<https://www.riigiteataja.ee/akt/13153518?leiaKehtiv>);
- Institutions of Professional Higher Education Act (<https://www.riigiteataja.ee/akt/13181429?leiaKehtiv>);
- Private Schools Act (<https://www.riigiteataja.ee/akt/111032015018?leiaKehtiv>);
- VET Institutions Act (<https://www.riigiteataja.ee/akt/102072013001?leiaKehtiv>);
- Standard of Higher Education (<https://www.riigiteataja.ee/akt/129072014017?leiaKehtiv>).

Starting from the 2002/2003 academic year the Estonian system of higher education comprises three cycles following the Bachelor-Master-PhD model of the EHEA.

3.3.2. Qualifications framework of higher education

Qualifications framework of higher education in Estonia is laid down by Standard of Higher Education (SHE) the regulation of the Government of the Republic (https://www.riigiteataja.ee/akt_seosed.html?id=129102013009&vstyt=TOLK). The SHE establishes the following uniform requirements for studies at higher education level:

- 1) Requirements for a curriculum, including requirements for a joint curriculum and requirements for studies and final paper or final examination;
- 2) The objectives of study and LOs and total volume of study, including the principles for RPL;
- 3) General requirements for qualification of the academic staff;
- 4) List of fields of study and specialisations;
- 5) The curriculum groups in which the respective higher education institution (HEIs) has the right offer programmes and award respective academic degrees and diplomas.

The LOs of higher education qualifications have been defined in compliance with the cycles of Qualifications Framework for the EHEA (QF-EHEA), and descriptions of levels 6-8 of the EQF. Nevertheless, the aim was not to copy any existing qualifications framework, but to develop the basis for improving the comparability of qualifications and streamline them with the needs of the society. It should be noted that QF-EHEA describes LOs on the average level or „a normal achievement of a successful learner“, while the SHE describes LOs on the basic level, i.e. any graduate must achieve these outcomes and „achievement of LOs on the level above minimum is differentiated by grading“.

The **Estonian qualifications framework of higher education** comprises four qualifications:

- **Bachelor's degree;**
- **Diploma of professional higher education;**
- **Master's degree;**
- **Doctoral degree.**

Bachelor's degree and diploma of professional higher education have a different focus but they are equal qualifications of the QF-EHEA first cycle. Master's degree complies with the QF-EHEA second cycle and Doctoral degree to the third cycle. All degrees offered by Estonian HEIs are end-of-cycle degrees, meaning that the LOs achieved are at the same qualification level as the corresponding level in the EstQF. This implies that there are no intermediate degrees in the Estonian higher education system.

3.3.3. Standard of higher education

As of 1st September 2009, all higher education study programmes are based on LOs (**Criterion 3 of the QF-EHEA**). Requirements to the inputs of higher education (qualification of academic staff, qualification granting entrance, duration of studies) and LOs are laid down in the SHE. Besides theoretical knowledge and skills, the expected LOs of the graduates of different qualification levels described in the standard also focus on the transferable competences that each graduate should have acquired by the end of his or her studies despite his or her speciality. For example, graduates are expected to have oral and written communication skills in addition to their mother tongue also in at least one foreign language, analysis and teamwork skills, skills of gathering and processing information, to demonstrate tolerance towards diversity of attitudes and values, to evaluate the consequences of his or her professional activities and preparedness for continuous individual development. On the other hand, there is no clear division of outcomes into knowledge, skills and scope of autonomy and responsibility as in the EstQF.

The LOs of higher education qualifications (see Table 3.3) have been defined in the SHE as „the knowledge, skills and attitudes acquired as a result of studies which are described at the minimum level which is necessary for the completion of a programme, module or subject“. It is difficult to draw a clear line between knowledge, skills and attitudes in real life. They are often intertwined, e.g. some skill can support the acquisition of knowledge, or it is impossible to develop skills from a certain level without supporting knowledge. No attempt has been made to differentiate between professional and transferable LOs.

Table 3.3. Learning outcomes of higher education qualifications

In order to be awarded a diploma of professional higher education, a student shall:	In order to be awarded a Bachelor's degree, a student shall:	In order to be awarded a Master's degree (including upon completion of the integrated study programmes of Bachelor's and Master's study), a student shall:	In order to be awarded a Doctoral degree, a student shall:
Have a systematic overview of the basic concepts, theoretical principles and research methods of the speciality;	Have a systematic overview of the basic concepts, theoretical principles, and research methods of the field of study;	Have a systematic overview and broad knowledge of the concepts, theories, and research methods of the field of study;	Have broad knowledge and a systematic overview within his or her field of research and in-depth and up-to-date knowledge within a narrower sphere of the field of research;
Recognise current problems and implementation possibilities of the speciality;	Recognise theoretical schools, development trends and current problems of the field of study;	Recognise theoretical development trends, current problems and potential applications of the speciality; Have in depth knowledge in a narrower research field of the speciality;	
Be able to identify interdisciplinary connections in the scope	Be able to identify interdisciplinary relationships;	Be able to identify and create interdisciplinary connections;	Understand the meaning and scope of the existing knowledge and research methods of the field of research and between

of application of different specialities;	Understand the scope of application of different specialities of the field of study;		fields so as to extend, reevaluate, and formulate them as necessary;
Be able to formulate problems relating to the speciality and analyse and evaluate different solutions;	Be able to formulate problems relating to the speciality and to analyse and evaluate different solutions;	Be able to independently and creatively identify and formulate problems and /or research questions related to the speciality and be able to solve them with appropriate measures within given timeframes and within limited information, taking advantage of the knowledge of other fields as necessary;	Be able to independently and critically analyse, synthesise, and evaluate new and complex ideas relating to the speciality, and creatively and with scientific accuracy identify and formulate research questions;
Be able to gather information independently by using appropriate methods and means and to interpret it critically and creatively;	Be able to gather information independently by using appropriate methods and means and to interpret it critically and creatively;	Be able to select and use appropriate technologies and methods when solving the problems of the speciality, and to model and/or assess the potential results;	Have command of research methods of his or her research field;
Be able to select and use appropriate technologies and methods when solving problems of the speciality within given frameworks, and to model and/or assess the potential results on the basis of the information given;	Be able to select and use appropriate technologies and methods when solving problems of the speciality;	Be able to critically evaluate his or her activities when solving problems and/or research questions of the speciality;	Be able to conceive, design, implement, and critically evaluate research and development projects that lead to new knowledge and new procedural solutions;
Show initiative in the launching of projects and responsibility, leadership and teamwork skills in implementation thereof;	Be willing to participate in teamwork and lead;	Be prepared to work in an area of activity that requires occupational qualification, showing initiative, responsibility, leadership, and teamwork skills;	Be able to independently act in a complex, including international work and study environment, including in research which requires leadership and team work skills, innovative thinking and the ability of making strategic decisions;
		Be able to hand down with competence his or	Be able to hand down with competence his or

		her knowledge by instruction, or another manner;	her knowledge by teaching, teaching, instruction, or in another manner;
Have command of the communication skills and information and communication technologies necessary for work;	Have command of the communication skills and information and communication technologies necessary for work;		
Be able to explain orally or in written form in the language of instruction and at least one foreign language problems relating to the speciality, and to participate in professional discussions;	Be able to explain orally or in written form in the language of instruction and at least one foreign language problems relating to the speciality and to participate in professional discussions;	Be able to present and reason orally or in written form in the language of instruction and a foreign language essential for his or her speciality the problems relating to the speciality, conclusions, and the underlying theories, and to participate in relevant discussions of both specialists and non-specialists;	Be able to present orally or in written form the problems and conclusions relating to the branch of science and his or her research, and the underlying theories, both to specialist audiences and in communication with non-specialists, and to present reasons and participate in relevant discussions in the language of instruction and a foreign language essential for his or her speciality, as well as to publish original scientific results in internationally pre-reviewed academic publications or, in art specialities, creative works for international audience;
Be willing to actively participate in civil society and demonstrate tolerance towards the diversity of attitudes and values;	Be willing to actively participate in civil society and demonstrate tolerance towards the diversity of attitudes and values;	Be willing to actively participate in civil society and demonstrate tolerance towards the diversity of attitudes and values;	Be able to analyse social norms and relationships, comply therewith, and act to change them as necessary;
Be able to evaluate the role and consequences of professional activities for the community, with consideration to social and ethical aspects;	Be able to evaluate the role of knowledge and the role and consequences of his or her professional activities in the community, with consideration to scientific, social and ethical aspects;	Be able to act ethically in complex situations, be aware of the ethical aspects, possibilities, restrictions and social role of his or her activities and be able to provide reasoned assessment in issues	Be able to provide scientific ethical assessments, show insight into the possibilities and limitations with science, the social role of science, and the responsibility of people in the use of scientific achievements;

concerning his or her speciality;			
Be able to apply the acquired knowledge and skills in work and be willing to engage as a specialist or undertaking in his or her speciality;	Be able to apply the acquired knowledge and skills in work;	Be able to continue studies or participate in research, act as a specialist or developer in his or her field, including internationally;	
Be able to undertake continuous independent professional development;	Be able to continue studies and to undertake continuous independent professional development;	Be able to evaluate his or her need, and the needs of others for continuing training and professional development, and have command of effective methods necessary for independent study;	Have the ability to identify his or her need for further knowledge or skills and support the studies of others both in the context of education and science as well as on a wider social level;

3.3.4. Assigning EstQF level to higher education qualifications

In the field of higher education the QF-EHEA and the EQF are used concurrently. The London communiqué (2007) of the ministers of education confirms the compatibility of these two frameworks in regard of higher education: “We are satisfied that national qualifications frameworks compatible with the overarching Framework for Qualifications of the EHEA will also be compatible with the proposal from the European Commission on a European Qualifications Framework for Lifelong Learning.” In Estonia the following processes took place concurrently:

- 1) Conformity assessment of the QF-EHEA and the EstQF-HE;
- 2) Referencing the EstQF-HE to the EstQF and through that also to the EQF.

Taking into account the comparability of the two frameworks of the European level and the fact that the QF-EHEA is more detailed and thus a more accurate basis for the conformity assessment of higher education qualifications, this framework has been taken as the basis for referencing.

To investigate the accordance between the EstQF-HE and the QF-EHEA, the self-certification committee conducted a conceptual analysis and comparison of the qualification level descriptors contained in the two frameworks.

Firstly, each descriptor from the QF-EHEA was compared with the descriptors in the EstQF-HE in order to assess their consistency both in content as well as level. There are no major differences in the level descriptions of the EstQF-HE and the QF-EHEA, although the EstQF-HE describes learning outcomes on minimum level and the QF-EHEA on average level. The committee noted that the terminology employed in the QF-EHEA is mostly more general than that of the EstQF-HE. In addition, there are several descriptors in the EstQF-HE not present in the QF-EHEA which was considered to be rather a positive than a negative aspect of the EstQF-HE as this shows that the EstQF-HE considers also national context and needs of society. The unique descriptors in the EstQF-HE are ability for teamwork, foreign language skills, interdisciplinary approach and teaching skills on Master and Doctoral levels.

Student workload in Estonian higher education has been measured in credit points since the beginning of 1990s. Since the 2009/2010 academic year, the European Credit Transfer and Accumulation System (ECTS)

has officially been in use. One ECTS credit point corresponds to 26 hours of work. The workload of one full-time academic year is 1,560 hours or 60 ECTS credit points.

In the credit point system valid until the 2009/2010 academic year, one credit point (*ainepunkt*, AP) corresponded to a workload of one week or 40 hours. The workload of one academic year was 40 AP, which now corresponds to 60 ECTS credit points.

The study load of Bachelor's study and Professional Higher Education programmes is from 180 to 240 ECTS credit points. The exception is midwifery studies and nursing studies with additional specialisations, the volume of which is 270 ECTS credit points. The study load of Master's study is from 60 to 120 ECTS credit points.

The study load of the Bachelor's study and Master's study together as well as studies in professional higher education and Master's study together shall be a minimum of 300 ECTS credit points.

The study load in integrated Bachelor's and Master's programmes is 300 ECTS credit points in most programmes, or 360 ECTS credit points in medical studies and veterinary studies.

The study load of a Doctoral study is 180 to 240 ECTS credit points by law, but in reality all doctoral programmes are 240 ECTS credit points, 180 ECTS credit points of which comprise doctoral thesis.

Based on the consistency analyses and general comparison, the committee considered that there are clear and demonstrable links between the EstQF-HE and the QF-EHEA (**Criterion 2 of the QF-EHEA**). All degrees in the EstQF-HE are end-of-cycle degrees (see Annex 2) and the work-load of respective qualifications is comparable to the QF-EHEA cycles (see Tables 3.4-3.8). There is a strong alignment between the descriptors used in the QF-EHEA and the EstQF-HE, and the differences merely stem from the level of detail and are of no significant consequence. Thus, the national framework and its qualifications are demonstrably based on LOs and the qualifications are linked to ECTS or ECTS compatible credits (**Criterion 3 of the QF-EHEA**).

Table 3.4. Comparison of LOs for the QF-EHEA first cycle qualifications and the EstQF-HE Bachelor's degree

QF-EHEA first cycle qualifications	EstQF-HE Bachelor's degree	Comments
Qualifications that signify completion of the first cycle are awarded to students who:	In order to be awarded a Bachelor's degree , a student shall:	
Have demonstrated knowledge and understanding in a field of study that builds upon their general secondary education, and is typically at a level that, whilst supported by advanced textbooks, includes some aspects that will be informed by knowledge of the forefront of their field of study;	Have a systematic overview of the basic concepts, theoretical principles, and research methods of the field of study;	In general, EstQF-HE is compatible with EHEA framework. EstQF-HE specifically emphasises the skill to identify interdisciplinary connections.
	Recognise theoretical schools, development trends and current problems of the field of study;	
	Be able to identify interdisciplinary relationships;	
Can apply their knowledge and understanding in a manner that indicates a professional	Understand the scope of application of different specialities of the field of study;	General preparedness for working has been provided last but one LO in the EstQF-HE as "is capable to

<p>approach to their work or vocation, and have competences typically demonstrated through devising and sustaining arguments and solving problems within their field of study;</p>	<p>Be able to formulate problems relating to the speciality and to analyse and evaluate different solutions;</p>	<p>the acquired knowledge and skills in work". EstQF-HE fails to specify clearly professional approach but instead emphasises the analysis and evaluation skills in regard of application of knowledge and separately points out the preparedness for teamwork. Besides preparedness to apply knowledge (QF-EHEA) these are the comprehensive Bachelor's studies (EstQF-HE) what should be as a rule followed by a narrower specialisation in the Master's programme. It is extremely important to acquire an understanding of the options for application of his or her speciality in case this understanding has not</p>
	<p>Be able to select and use appropriate technologies and methods when solving problems of the speciality, among other things, be willing to participate in teamwork and supervise it;</p>	
<p>Have the ability to gather and interpret relevant data (usually within their field of study) to form judgments that include reflection on relevant social, scientific or ethical issues;</p>	<p>Be able to collect information independently using appropriate methods and means and to interpret it critically and creatively;</p>	<p>Similar LOs</p>
	<p>Be able to evaluate the role of knowledge and the role and consequences of his or her professional activities in the society with consideration of scientific, social and ethical aspects;</p>	
<p>Current situation, related problems and projects: solutions to both specialist and non-specialist audiences;</p>	<p>Have command of the communication skills and information and communication technologies necessary for work;</p>	<p>QF-EHEA emphasises audiences of non-specialists while EstQF-HE stresses ICT skills and skills in speciality specific foreign language.</p>
	<p>Be able to explain orally or in written form in the language of instruction and at least one foreign language problems relating to the field of study, and to participate in professional discussions;</p>	
<p>Have developed those learning skills that are necessary for them to continue to undertake further study with a high degree of autonomy</p>	<p>Be capable to apply the acquired knowledge and skills in work, to continue studies and to undertake continuous independent professional development</p>	<p>This LO in the EstQF-HE stresses both preparedness for undertaking work, as well as for continuing studies</p>
	<p>Be willing to actively participate in the civil society and demonstrate tolerance towards diversity of attitudes and values;</p>	<p>Unique in the EstQF-HE</p>

Table 3.5. Comparison of LOs for the QF-EHEA first cycle qualifications and the EstQF-HE diploma of professional higher education

QF-EHEA first cycle qualification	EstQF-HE diploma of professional higher education	Comments
Qualifications that signify completion of the first cycle are awarded to students who:	In order to be awarded a diploma of professional higher education , a student shall:	
Have demonstrated knowledge and understanding in a field of study that builds upon their general secondary education, and is typically at a level that, whilst supported by advanced textbooks, includes some aspects that will be informed by knowledge of the forefront of their field of study;	Have a systematic overview of the basic concepts, theoretical principles and research methods of the speciality;	In general, EstQF-HE is compatible with QF-EHEA. EstQF-HE makes a separate reference to the ability to identify interdisciplinary connections.
	Be able to identify interdisciplinary connections in the scope of application of different specialities;	
	Recognise current problems and implementation possibilities of the speciality;	
Can apply their knowledge and understanding in a manner that indicates a professional approach to their work or vocation, and have competences typically demonstrated through devising and sustaining arguments and solving problems within their field of study;	Be able to apply the acquired knowledge and skills in work and be willing to engage as a specialist or undertaking in his or her speciality;	As the professional higher education is first oriented towards labour market, EstQF-HE provides a detailed view of the skills regarding application of knowledge, stressing, inter alia, initiative, responsibility, leadership and team work skills which in QF-EHEA have been summarised under professional approach.
	Show initiative in launching of projects and responsibility, leadership and team work skills in implementation thereof;	
	Be able to formulate problems relating to the specialty and to analyse and evaluate different solutions;	
	Be able to select and use appropriate technologies and methods when solving problems of the speciality within given frameworks, and to model and/or assess the potential results on the basis of given information;	
Have the ability to gather and interpret relevant data (usually within their field of study) to form judgments that include reflection on relevant social, scientific or ethical issues;	Be able to gather information independently by using appropriate methods and means and to interpret it critically and creatively;	Similar LOs
	Be able to evaluate the role and consequences of professional activities for the society with consideration of social and ethical aspects;	
Current situation, related problems and projects: solutions	Have command of the communication skills and	QF-EHEA emphasises audiences of non-specialists while EstQF-HE

to both specialist and non-specialist audiences;	information and communication technologies necessary for work;	ICT skills and skills in specialised foreign language.
	Be capable to explain orally or in written form in the language of instruction and at least one foreign language problems relating to the speciality, and to participate in professional discussions;	
Have developed those learning skills that are necessary for them to continue to undertake further study with a high degree of autonomy	Be able to undertake continuous independent professional development;	Similar LOs
	Be willing to actively participate in the civil society and demonstrate tolerance towards diversity of attitudes and values;	Unique in EstQF-HE

Table 3.6. Comparison of LOs for the QF-EHEA second cycle qualifications and the EstQF-HE Master's degree

QF-EHEA second cycle qualifications	EstQF-HE Master's degree	Comments
Qualifications that signify completion of the second cycle are awarded to students who:	In order to be awarded a Master's degree (including upon completion of the integrated curricula of Bachelor's and Master's study), a student shall:	
Have demonstrated knowledge and understanding that is founded upon and extends and/or enhances that typically associated with the first cycle, and that provides a basis or opportunity for originality in developing and/or applying ideas, often within a research context;	Have a systematic overview and broad knowledge of the concepts, theories, and research methods of the field of study;	EstQF-HE highlights some LOs of the first cycle as for the integrated Bachelor's and Master's study programme these are the only standards. Originality stressed in QF-EHEA has been pointed out in EstQF-HE as creativity.
	Recognise theoretical development trends, current problems and potential applications of the speciality;	
	Have in depth-knowledge in a narrower research field of the speciality;	
	Be able to independently and creatively identify and formulate problems and /or research questions related to the speciality;	
	Participate in research, act as a specialist or developer in his or her field, including internationally	
Can apply their knowledge and understanding, and problem	Be able to identify and create interdisciplinary connections;	Similar LOs

<p>solving abilities in new or unfamiliar environments within broader (or multidisciplinary) contexts related to their field of study;</p>	<p>Be able to select and use appropriate technologies and methods when solving problems of the speciality, and to model and/or assess the potential results;</p>	
	<p>Be capable to solve them (problems) with appropriate measures within given timeframes and within limited information, taking advantage of knowledge of other fields as necessary;</p>	
<p>Have the ability to integrate knowledge and handle complexity, and formulate judgments with incomplete or limited information, but that include reflecting on social and ethical responsibilities linked to the application of their knowledge and judgments;</p>	<p>Be able to independently and creatively identify and formulate problems and /or research questions related to the speciality and be capable to solve them with appropriate measures within given timeframes and within limited information, taking advantage of knowledge of other fields as necessary;</p>	<p>Similar LOs, EstQF-HE adds the ability to evaluate critically his or her activities.</p>
	<p>Be able to critically evaluate his or her activities when solving problems and/or research questions of the speciality;</p>	
	<p>Be able to act ethically in complex situations, be aware of the ethical aspects, possibilities, restrictions and social role of his or her activities and be able to provide reasoned assessment in issues concerning his or her speciality;</p>	
<p>Can communicate their conclusions, and the knowledge and rationale underpinning these, to specialist and non-specialist audiences clearly and unambiguously;</p>	<p>Be capable to present and reason orally or in written form in the language of instruction and a foreign language essential for his or her speciality the problems relating to the speciality, conclusions and the underlying theories, and to participate in relevant discussions of both corresponding specialists and non-specialists;</p>	<p>Similar LOs</p>
<p>Have the learning skills to allow them to continue to study in a manner that may be largely self-directed or autonomous.</p>	<p>Be able to evaluate his or her need, and the need of others, of continuing training and professional development, and have command of effective methods necessary for independent study;</p>	<p>Similar LOs</p>
	<p>Be able to continue studies or participate in research;</p>	

	Be able to hand down with competence his or her knowledge by teaching, instruction or in another manner;	Unique in EstQF-HE
	Be willing to actively participate in the civil society and demonstrate tolerance towards diversity of attitudes and values;	Unique in EstQF-HE

Table 3.7. Comparison of LOs for the QF-EHEA third cycle qualifications and the EstQF-HE Doctoral degree

QF-EHEA third cycle qualifications	EstQF-HE Doctoral level degree	Comments
Qualifications that signify completion of the third cycle are awarded to students who:	In order to be awarded a Doctoral level degree, a student shall:	
Have demonstrated a systematic understanding of a field of study and mastery of the skills and methods of research associated with that field	Have broad knowledge and systematic overview within his or her field of research and in-depth and up-to-date knowledge within a narrower sphere of the field of research;	Similar LOs
	Have command of research methods of his or her research field;	
Have demonstrated the ability to conceive, design, implement and adapt a substantial process of research with scholarly integrity	Understand the meaning and scope of the existing knowledge and research methods of the field of research and between fields so as to extend, reevaluate and formulate them as necessary;	EstQF-HE is more specific, emphasising interdisciplinary qualities and management and teamwork skills.
	Be able to independently act in a complex, including international work and study environment, including in research which requires leadership and team work skills, innovative thinking and the ability of making strategic decisions;	
Have made a contribution through original research that extends the frontier of knowledge by developing a substantial body of work, some of which merits national or international refereed publication	Be able to conceive, design, implement and critically evaluate research and development projects that lead to new knowledge and new procedural solutions;	Similar LOs
	to publish original scientific results in internationally pre-reviewed academic publications or, in art specialities, creative works for international audience;	

Are capable of critical analysis, evaluation and synthesis of new and complex ideas	Be able to independently and critically analyse, synthesise and evaluate new and complex ideas relating to the speciality, and creatively and with scientific accuracy identify and formulate research questions;	Similar LOs
Can communicate with their peers, the larger scholarly community and with society in general about their areas of expertise	be capable to present orally or in written form the problems and conclusions relating to the branch of science and his or her research, and the underlying theories, both to specialist audiences and in communication with non-specialists, and to present reasons and participate in relevant discussions in the language of instruction and a foreign language essential for his or her speciality;	Similar LOs, EstQF-HE emphasises proficiency in foreign language.
Can be expected to be able to promote, within academic and professional contexts, technological, social or cultural advancement in a knowledge based society	Be able to provide scientific ethical assessments, show insight into the possibilities and limitations with science, the social role of science and the responsibility of people in the use of scientific achievements;	Similar LOs, EstQF-HE emphasises application of science in a society and teaching skills, QF-EHEA is more comprehensive in scope, stressing also preparedness to participate in the technological and cultural development of the society.
	Be able to analyse social norms and relationships, comply therewith and act to change them as necessary;	
	Be able to hand down with competence his or her knowledge by teaching, instruction or in another manner;	
	Have an ability to identify his or her need of further knowledge or skills and support the studies of others both in the context of education and science as well as on a wider social level;	Unique in EstQF-HE

Table 3.8. Workload in credit points in the EstQF-HE and the QF-EHEA

FQ-EHEA		Estonian NQF	
Qualification	Workload	Qualification	Workload
Short cycle qualification – within or linked to the first cycle	Approximately 120 ECTS credits	N.A.	N.A.

First cycle	Typically include 180–240 ECTS credits	Bachelor's degree	180–240 ECTS*
		Diploma of studies in professional higher education	180–270 ECTS*
Second cycle	Typically include 180–240 ECTS credits, with a minimum of 60 credits at the level of the 2nd cycle	Master's degree	60–120 ECTS*
		Integrated Bachelor's and Master's degree	300–360 ECTS
Third cycle	Not specified	Doctoral level degree	180-240 ECTS

*) Bachelor's or professional higher education programmes and Master's study programmes must total at least 300 ECTS.

To summarise, it can be concluded that:

- 1) **Bachelor's degree and diploma of professional higher education are the qualifications of level 6 of the EstQF;**
- 2) **Master's degree and diploma on integrated higher education are the qualifications of level 7 of the EstQF;**
- 3) **Doctoral degree is level 8 qualification of the EstQF.**

The self-certification committee will inform the Estonian ENIC-NARIC when the self-certification process is completed in order for Estonia to be included in the list of countries that have completed the self-certification process (*Procedure 5 of the QF-EHEA*). The final version of the report will be published on the MoER website (www.hm.ee), on the EstQA website (www.kutsekoda.ee) and on the ENIC/NARIC website (www.archimedes.ee/enic) (*Procedure 4 of the QF-EHEA*).

3.3.5. Institutions awarding higher education qualifications and awarding of qualifications

Higher education qualifications are awarded by the universities, institutions of professional higher education and a few VET institutions, where the studies are based on programmes of professional higher education. The schools are entitled to issue only national graduation certificates: external quality assessment is the basis for granting the right to award national graduation documents. See Clause 3.3.8 on the quality assurance of the Estonian higher education system and changes therein.

Study programmes of higher education and corresponding qualifications are entered into the EHS on the basis of the group and field of studies. The list of existing degree types specifying the level and field of qualification (e.g. Bachelor of Social Science) is described in the SHE.

Establishment of new types of qualifications happens at the legislative level, after which they will be included in the respective annex of the SHE. With the development of new curricula the compliance of programme LOs with the EstQF-HE shall be proved. Compliance is evaluated on two levels:

- (1) The HEI has internal procedures for designing and approving the study programme. According to the SHE the study programme must be “in compliance with the courses of action of the educational institution, which are based on the development plans, agreements of cooperation, or statutes of the educational institution” and help to “assist in the fulfilment of the mission of the educational institution and the achievement of the objectives and consider the needs of the labour

market and target group.” At the same time, the implementation of the study programme must “conform to the internal quality standards of the educational institution and national and international quality requirements and agreements”. The study programme is approved by the Council of the HEI.

- (2) The committee formed by a directive from the minister of education and research shall evaluate the conformity of the programme to the requirements of the HES. The committee shall also decide into which study programme group the study programme belongs. The basis for this is provided by the statutes of the EHIS. If the HEI lacks the right to conduct instruction in the given study programme group, the procedure is then stricter and defined by the Universities Act.

If the requirements are met, the programme will be included in the EHIS. The responsibility for this lies with the MoER.

Compliance between the programme LOs and the EstQF-HE for on-going programmes has been assessed during the transitional evaluation of programme groups. The procedures for this process are described on the website of the EKKA (http://ekka.archimedes.ee/wp-content/uploads/UHKordushindamine_muudatused_13.06.12_EN.pdf).

The self-certification committee has investigated the procedures for the inclusion of qualifications, understood as both the inclusion of new degree types and as the inclusion of new programmes, and acknowledges the transparency of these procedures (*Criterion 4 of the QF-EHEA*).

3.3.6. Recognition of prior learning in higher education

The SHE stipulates the aims and general principles for RPL in very broad terms. More specific regulations are adopted by HEIs. RPL may be applied:

- 1) to fulfil the admission requirements established by the HEI;
- 2) for transfer of credits;
- 3) for calculation of prior LOs and professional experience into credits.

The Government regulation “Statutes and forms of diploma and diploma supplement” (<https://www.riigiteataja.ee/akt/13169943?leiaKehtiv>) stipulates how the RPL shall be reflected in the Diploma Supplement (DS). The subjects and modules shall be indicated that have been completed using RPL and marked how the prior learning (formal, non-formal or informal) has taken place. The indication “recognised on the basis of prior learning” shall be added to the subject/module in the DS.

There has been a programme for the RPL development since 2003 in the framework of LÜKKA project (http://www.ut.ee/lykka/set_lang_id=2) and since 2008 under the Primus programme (<http://primus.archimedes.ee/>) both supported by European Social Fund (ESF). As a result, the network of RPL professionals of various specialities has been created, gathering statistics on RPL, and developing the guideline materials for applicants, assessors and consultants. For students and other interested persons a web-portal <http://vota.archimedes.ee/>, as well as an e-course “Introduction to RPL” is available.

3.3.7. Qualification certificates of higher education

The forms of diplomas and DSs certifying the graduation from a HEI, statute and the procedure for awarding thereof has been established by the Government regulation “Statutes and forms of diploma and diploma supplement” (2009) (<https://www.riigiteataja.ee/akt/13169943?leiaKehtiv>). Diploma is issued to a person who has completed a nationally recognised programme of the Bachelor's study, Master's study,

Doctoral studies and integrated curricula of Bachelor's and Master's study or professional higher education study in the full extent. The right and obligation to issue a respective diploma lies with the HEI providing studies based on the corresponding programme.

Following the above mentioned regulation, the HEI shall include the following information in the Estonian-language academic transcript or the English-language DS: “The qualification level (according to the EstQF and the EQF)” and “the content of the study programme and the results of its fulfilment (student workload, conditions for the fulfilment of the study programme (including the LOs of the study programme))” and “the description of the Estonian higher education system”. Pursuant to the same regulation, this information is added to the academic transcript and the DS as of 1st January 2012.

Therefore, the academic transcript connects specific qualification with both the EstQF and the EQF. In addition, the description of the Estonian higher education system, which is included in the DS, refers to the conformity of the European and Estonian qualifications frameworks (**Criterion 6, Procedure 6 of the QF-EHEA**).

3.3.8. Quality assurance system of higher education

Since 2009, the higher education quality has been assessed by an independent Estonian Higher Education Quality Agency (EKKA) established based on the Universities Act. The responsibility of the agency is to conduct institutional accreditation of HEIs and quality assessment of study programme groups.

The responsibilities of the EKKA and the main principles of external quality assurance are in full accordance with the European Standards and Guidelines for Quality Assurance in the European Higher Education Area (ESG). In fact, ESG has been the cornerstone in the formulation of responsibilities of the EKKA, including the principles for institutional accreditation and the quality assessment of study programme groups. The EKKA was successfully evaluated by the European Network for Quality Assurance in February 2013, and included into the [European Quality Assurance Register for Higher Education](#) (EQAR).

Until January 1st, 2010, external assessment of study programmes resulted in adopting of accreditation decisions. Full accreditation was granted for seven years; conditional accreditation is valid for three years.

From 2009 to 2012, the MoER implemented the transition from the former accreditation system, in which individual study programmes were accredited, to the quality assessment of study programme groups. There are altogether 28 study programme groups divided between 8 broad areas of study, based on ISCED 97. Study programme groups with respective degree types are defined in annex 3 of the SHE. This period has been called transitional evaluation. The conditions and the procedure for transitional evaluation (including the time schedule) were established by Order of the MoER of 6th May 2009. The EKKA Quality Assessment Council has laid down the requirements for the transitional evaluation and the procedure for its implementation.

The study programme groups were assessed from three aspects: quality, resources, and sustainability of studies. One of the main prerequisites for an institution to succeed in the transitional evaluation and in the future quality assessment of study programme groups is compliance of study programmes' LOs with the EstQF-HE (**Criterion 5 of the QF-EHEA**).

On the basis of external assessment, the Government of the Republic shall grant the HEI the right, for an indefinite or a fixed (1 to 3 years) period of time, to conduct studies according to the programme belonging to the respective study programme group. One of the options is to refuse from granting this right.

Pursuant to the Universities Act, institutional accreditation and quality assessment of study programme groups can be requested and carried out as of 1 January 2010, provided that the relevant institution of higher education has been granted the right to conduct studies at least in one study programme group at the higher education level. Actually, the EKKKA conducts institutional accreditation of HEIs and assessment of the quality of a study programme groups since 2012. **Institutional accreditation of a HEI** is an external evaluation during which the internal quality assurance system of the institution and its functioning are assessed, including the fulfilment of tasks the HEI has been entrusted with and the conformity of its management, administration, study and research environment to the objectives and development plan of the institution.

Assessment of the quality of a study programme group is evaluation of the conformity of the study programmes belonging to the study programme group and the instruction provided on the basis thereof to legislation as well as to national and international standards, including the level of the corresponding theoretical and practical instruction, the research and pedagogical qualification of the academic staff, as well as the sufficiency and sustainability of resources for the provision of instruction.

3.3.9. Responsibilities of national institutions

The main responsibility in implementing the EstQF-HE relies with the MoER. Other parties involved are:

- 1) the EKKKA, who through the quality assessment of study programme groups shall ensure that the alignment of specific study programmes with the descriptions of LOs in the EstQF-HE is in place;
- 2) Estonian ENIC/NARIC office, which has been designated as the national information point for the EstQF-HE.

Responsibility for the implementation of the EstQF-HE at the programme level rests with the HEI. The HEI is responsible for incorporating LOs in line with the EstQF-HE in their study programmes, and assuring the quality of studies.

This division of responsibilities is defined in the Estonian legislation (***Criterion 7 of QF-EHEA***).

3.4. Sub-framework of occupational qualifications

Occupational qualifications form a realm that is substantially different from the qualifications of formal education. The development and administration in this sphere of qualifications is the responsibility of the *Sihtasutus Kutsekoda* (Estonian Qualifications Authority (EstQA)).

3.4.1. Legal framework of the occupational qualifications system

Legal basis for the operation of the occupational qualifications system is specified in the Occupational Qualifications Act that entered into force 01.09.08 (<https://www.riigiteataja.ee/akt/13147615?leiaKehtiv>). This Act provides the bases for the development, operation and quality assurance of the occupational qualifications system. Based on this act the following legal acts have been issued:

- List of areas of occupational activity, the names of sector skills councils, the procedure for the formation and termination thereof, the organisation of activities, and the procedure for appointment of representatives of institutions (regulation of the Government of the Republic <https://www.riigiteataja.ee/akt/13091006>);
- The procedure for the organisation of the public competition and the list of documents certifying compliance with the conditions to be an institution awarding occupational qualification (regulation of the Government of the Republic <https://www.riigiteataja.ee/akt/13214816>);
- The statutes of the register of occupational qualifications (regulation of the Government of the Republic <https://www.riigiteataja.ee/akt/13185447>);
- The procedure for the preparation, amendment and recording of occupational qualification standards (regulation of the MoER <https://www.riigiteataja.ee/akt/13080263>);
- The statute and form of the occupational qualification certificate (regulation of the MoER <https://www.riigiteataja.ee/akt/13097607>).

3.4.2. Framework of occupational qualifications

Based on the Occupational Qualifications Act adopted in 2001 occupational qualifications were referenced to the 5-level occupational qualifications framework. The Occupational Qualifications Act adopted in 2008 stipulates the 8-level EstQF. Based on this legal act, the 8-levels occupational qualifications framework has been developed by the working group convened by the EstQA (see Table 3.6) and approved by the Board of the Chairmen of Sector Skills Councils (BCSSC) (see Annex 3). Occupational qualifications specific level descriptions of this framework are compatible with the level descriptions of the EstQF.

Table 3.9. General descriptions of occupational qualifications

EstQF level	Knowledge and understanding	Skills	Scope of independence and responsibility
Level 1	Owns basic work knowledge.	Performs <u>uncomplicated routine tasks</u> observing set procedures and detailed guidelines. Uses appropriate tools.	Works in a <u>limited situation</u> under a direct guidance. Is responsible for the performance of the duties.

Level 2	Owns basic work knowledge.	Performs <u>uncomplicated</u> tasks observing set procedures and guidelines. Selects and uses appropriate tools and equipment.	Works in a <u>fixed</u> situation with a certain degree of independence. Is responsible for the performance of the duties.
Level 3	Understands basic facts and principles regarding work. Knows basic work techniques.	Performs <u>basic</u> tasks. Selects and uses tools and methods. Acts according to plans, in a sparing and effective manner.	Works in a <u>generally fixed situation independently</u> . Organises his or her actions and adjusts it according to the situation. Participates in teamwork efficiently. Is responsible for the performance of the duties.
Level 4	Interprets and integrates extensive work-related knowledge and uses them in new situations.	Performs <u>basic</u> tasks. If necessary, initiates, prepares and adjusts appropriate changes. Acts and organises work according to plans, in a sparing and effective manner. Selects and uses tools and methods for performing common and novel tasks.	Works independently in <u>situations what can be usually foreseen but that can also change</u> . Supervises common work made by others and takes some responsibility for the development of others.
Level 5	Analyses information and approaches. Uses knowledge for creative solving of abstract tasks within limits of interconnected areas.	Performs <u>diverse</u> tasks, plans appropriate changes and organises application thereof. Selects and applies technologies, methods and tools for obtaining new solutions and adjusts his or her behaviour according to the situation.	Works independently in <u>unpredictable</u> situations. Takes responsibility for a small workgroup.
Level 6	Analyses and assesses facts, theories, principles and methods. Uses knowledge for creative solving of abstract tasks in interconnected areas.	Performs <u>complicated</u> tasks assuming novel approach and excellence. Intertwines activities and methods and assesses their potential results. Makes decisions on the basis of partial information.	Works independently in <u>complicated and unpredictable</u> situations. Takes responsibility for workgroups.
Level 7	Integrates novel knowledge in his or her work area based on original thinking. Creates new knowledge within the framework of fixed time and in the condition of limited time.	Solves <u>unpredictable and complicated</u> tasks In science, innovation and other areas creating new knowledge.	Works independently in complicated and unpredictable situations requiring <u>innovative approach</u> . Is responsible for contributing to professional knowledge or professional activities.

	Creates new methodologies, methods and technologies.	Initiates and plans activities and methods and analyses their short-and long-term consequences.	Is responsible for the strategic actions of teams.
Level 8	Works independently in complicated and unpredictable situations requiring <u>innovative approach</u> . Is responsible for contributing to professional knowledge or professional activities. Is responsible for the strategic actions of teams.	Solves <u>unique</u> tasks in science, innovation and other areas creating new knowledge. Initiates, plans and implements strategic research and development activities that enlarge the realm of work or knowledge or that result in considerable changes.	Works independently in complicated, <u>undefined situations requiring new strategic approach</u> that require excellence. Is responsible for the planning and development of the work or knowledge area. Analyses and synthesises independently new and complicated professional ideas. Is responsible for the strategic performance of an organisation.

3.4.3. Occupational qualification standards

An occupational qualification standard (OQS) is the focal element of the occupational qualifications system, which describes occupational activities and provides competence requirements for occupational qualifications. OQS consist of three parts (A, B and C part). Part A gives general description of the profession, incl. reference to the EstQF. Part B is the principal part of OQS describing expected competences in terms of LOs (performance indicators and knowledge). Part C gives information about dates of validity of the OQS, awarding institutions, etc.

The OQS is the basis for compiling national curricula in the field of VET, curricula for higher education and other training programmes, and for assessment of individuals' competence, incl. self-assessment and awarding an occupational qualification. OQSs are available in the State register of occupational qualifications (<http://www.kutsekoda.ee/en/kutseregister>).

3.4.4. Assigning the EstQF level to occupational qualifications

Assigning the EstQF level to an occupational qualification is accomplished in the process of OQS development. This procedure includes the following steps:

Assigning the EstQF level to competences

Part B of a OQS describes expected competences of the respective qualification. Performance indicators and knowledge describing a competence are compared with occupational qualification level descriptions (see Table 3.6) and based on the principle of best fit an EstQF level is assigned to all competences. Competences of an occupational qualification may have different EstQF level.

Assigning the EstQF level to occupational qualifications

- 1) If all competences of a qualification have the same EstQF level, a qualification is assigned this EstQF level;

- 2) If a qualification contains competences with different EstQF levels, the importance of competences is analysed and a weight is assigned to each competence using a 2-point scale (important-very important);
- 3) The EstQF level of the qualification is calculated as weighted average of the EstQF levels of competences and rounded to the closest integer.

Approving the EstQF level of occupational qualifications

- 1) Working group developing the OQS proposes EstQF level of the corresponding qualification using the above procedure;
- 2) Proposal of the working group is reviewed by the EstQA expert group;
- 3) Proposal approved by the EstQA expert group is sent for review to the MoER;
- 4) The BCPC assigns the EstQF level to the occupational qualification;
- 5) the SSC approves the OQS with assigned EstQF level.

All OQSs developed since 2009 include reference to the EstQF level. The EstQF level has been assigned to OQSs developed during the period 2002-2009 and initially referenced to the 5-level occupational qualifications framework, which serve as:

- 1) the basis for awarding occupational qualification certificates for an unspecified term;
- 2) the basis for developing curricula.

The occupational qualification certificates and their registration numbers shall continue to be valid. The EstQF level of these occupational qualifications is available in the register of occupational qualifications (<http://www.kutsekoda.ee/et/kutregister>).

For referencing occupational qualifications to the EstQF working groups have been established, including specialists of the respective field. The working groups followed the methodology approved by the BCSSC.

3.4.5. Institutions awarding occupational qualifications and awarding process

Pursuant to the Occupational Qualifications Act institutions awarding occupational qualifications (IAOQ) are legal entities or authorities that have been granted the right to award occupational qualification based on one or several OQSs (see Annex 3). The granting of rights to an IAOQ is decided by the SSC of the respective area of occupational activity.

To ensure impartiality in awarding occupational qualifications, the IAOQ shall set up an occupational qualifications committee that shall consist of the representatives of stakeholders in the given field: specialists, employers, employees, trainers, representatives of professional associations and, if necessary, representatives of clients, as well as other interested parties.

The rules for the awarding of occupational qualification describe general requirements for the awarding process and the procedure for the application and methods for assessing the applicants' competence.

3.4.6. Occupational qualification certificates

In order for an occupational qualification certificate to be included into the register of occupational qualifications the following conditions have to be met:

- 1) a LOs (competence) based OQS has been drawn up;
- 2) the basis for the conformity assessment of a persons' competence has been described;
- 3) there is a recognised IAOQ.

The register of occupational qualifications contains the following data regarding occupational qualification certificates:

- 1) Institution awarding the qualification;
- 2) Occupational qualification and its' EstQF level;
- 3) Registration number of the certificate;
- 4) Specialisation(s) (if applicable);
- 5) The date of passing the decision to award the occupational qualification;
- 6) Personal data of the owner of the occupational qualification certificate;
- 7) The date of issue of the occupational qualification certificate;
- 8) The closing date of validity of the occupational qualification certificate.

3.4.7. Recognition of prior learning in awarding the occupational qualification

In the process of awarding of occupational qualification the assessment committee, established by occupational qualification committee shall assess the compliance of the competence of the applicant to the requirements of the OQS based on the criteria, described in the rules and procedures for awarding the qualification. The occupational competence of a person is assessed and recognised despite the fact whether this has been obtained from formal, non-formal or informal learning. RPL provides the applicant an opportunity to apply for the occupational qualification using appropriate methods and evidence, avoiding assessment and validation of the competences that have been assessed and validated earlier.

3.4.8. Quality assurance in the system of occupational qualifications

Ensuring quality in the occupational qualifications system includes:

- 1) Ensuring the quality of occupational qualification standards;
- 2) Ensuring the quality of granting the IAOQ the right to award occupational qualifications;
- 3) Ensuring the quality of assessment and validation of applicant's competence by the IAOQ;
- 4) Periodic external assessment of the IAOQ by the EstQA.

Respective principles and procedures have been established in the Occupational Qualifications Act that in turn proceeds from the requirements of ISO 17924 (general requirements for personal certification).

The quality of occupational qualifications is assured through the use of state recognised occupational qualification standards (included into the state register of occupational qualifications), and assessment, validation and certification conducted under the auspices of accredited awarding institution (accredited by the respective SSC).

Conclusions

The process of establishing the EstQF and referencing it to the EQF has provided an important impulse for the development of life-long learning system in Estonia, for the establishment of national qualifications system and quality assurance system for life-long learning. In the course of this process a remarkable convergence of the formal educational system and occupational qualifications system has taken place.

Unlike numerous other Member States of the European Union, occupational qualifications are also placed into the EstQF and through that referenced to the EQF. This is made possible by the consistent application of LOs based (competence-based) approach in the occupational qualifications system and national governance of this system, ensuring the quality of the awarding of occupational qualifications and comparability thereof on the international level.

Issues decided but not implemented yet

- 1) All items mentioned in the previous version of the report under this title have been implemented.
- 2) Following the new Adult Education Act (<https://www.riigiteataja.ee/en/eli/529062015007/consolide>), the quality of adult learning is increased through introduction of LOs based approach into the adult learning curriculum design, implementation and assessment.
- 3) The occupational qualifications system will be amended with a subsystem for quantitative and qualitative monitoring, analysis and forecasting of labour market needs (). This subsystem is under development sector-wise during the period 2015-2020.

Annex 1. Composition of the Steering Committee

The composition of the steering committee approved by the Directive no. 925 of the minister of education and research of 04.10.2010:

- 1) Janar Holm Chairman of the Committee, MoER, Secretary General
- 2) Kalle Küttis Vice-chairman of the Committee, MoER, Deputy Secretary General, General and Vocational Education
- 3) Olav Aarna EstQA, Member of the Board
- 4) Külli All MoER, Vocational and Adult Education Department, Adviser
- 5) Anu Altermann Ministry of Finance, Public Administration and Public Service Department, Adviser
- 6) Heli Aru MoER, Education and Labour Market Adviser
- 7) Katrin Höövelson State Chancellery, Strategy Bureau, Adviser
- 8) Monika Maljukov Federation of Estonian Student Unions, Educational policy officer
- 9) Kerstin Peterson Ministry of Social Affairs, Department of Labour Market, Adviser
- 10) Andres Pung MoER, Vocational and Adult Education Department, Head of Department
- 11) Tiia Randma Estonian Chamber of Commerce and Industry, Adviser for education
- 12) Edgar Rootalu Estonian Association of Pupils' Unions, Head of educational policy
- 13) Kaja Toomsalu Confederation of Estonian Trade Unions, Wages Secretary
- 14) Ago Tuuling Public Servants Trade Unions Central Organization TALO, Chairman of the Board
- 15) Gunnar Vaht ENIC/NARIC Centre, Head of the Centre

Composition of the Bologna self-certification committee:

- 1) Mart Laidmets MoER, Department of Higher Education, Head of the department
- 2) Gunnar Vaht ENIC/NARIC Centre, Head of the Centre
- 3) Tiia Kurvits MoER, Department of Higher Education, Chief expert
- 4) Heli Aru MoER, Education and Labour Market, Adviser
- 5) Kairi Solmann Rectors Council of Estonia, Director
- 6) Anneli Lorenz Archimedes Foundation, Head of department
- 7) Olav Aarna EstQA, Member of the Board
- 8) Helena Gussarova Rectors Council of Universities of Applied Sciences of Estonia
- 9) Heli Mattisen EKKA, Director
- 10) Maris Mälzer Estonian Association of Student Unions, President.

Amendments to the steering committee approved by the Directive no. 630 of the minister of education and research of 09.08.2011:

a. New members of the steering group:

- 1) Tiina Annus MoER, Department of Analysis, Head of the Department
- 2) Irene Käosaar MoER, Department of General Education, Head of the department
- 3) Mart Laidmets MoER, Department of Higher Education, Head of the department
- 4) Helen Põllo MoER, Department of Higher Education, Chief expert
- 5) Maiki Udam EKKA, Development manager, Bologna expert

- b. Representative of the Ministry of Finance Anu Altermann is excluded from the steering group;
- c. Kersti Holland, adviser to the department of labour is nominated as the representative of the Ministry of Social Affairs.

Annex 2. Estonian formal education system

A2.1. Structure and legal framework of the formal education system

Estonian formal education system comprises the following parts:

- General education,
- VET,
- Higher education.

The structure of formal education system in Estonia is presented in Figure A2.1.

The formation, operation and development of the educational system is stipulated by the **Republic of Estonia Education Act** (1992) (<https://www.riigiteataja.ee/akt/13198443?leiaKehtiv>). The educational levels specified in the Education Act are: pre-school education (level 0), basic education (level I), secondary education (level II) and higher education (level III). For each educational level there are **educational standards** fixed.

Estonian educational legislation is mostly based on the types of educational institutions (see Clauses 3.1-3.3).

The development and operation of the formal education system is governed by:

- *Riigikogu* (the Parliament),
- Government of the Republic,
- Ministry of Education and Research,
- Local municipalities.

A2.2. General education

General education comprises the following educational levels listed in the Education Act: pre-school education, basic education and secondary education.

Options and forms for providing pre-school education are regulated in the Pre-school Child Care Institutions Act and the contents in the National Curriculum of the Pre-school Child Care Institution. Studying in a pre-school child care institution is not mandatory. It is still recommended to achieve the social preparedness required for entering into the basic school and competences listed in the national curriculum of the pre-school child care institution which are prerequisites for successful progress at school. Therefore, almost 95% of 5-7 years old children attend kindergarten.

Acquiring education is one of the fundamental rights of the citizens living in Estonia and as far as basic education is concerned it is also compulsory. A child is subject to the obligation to attend school starting from the age of 7 until he or she acquires basic education or attains 17 years of age. Basic education is the compulsory minimum general education prescribed by the National Curriculum for Basic Schools the acquisition of which creates prerequisites and grants the right to continue studies for acquiring secondary education.

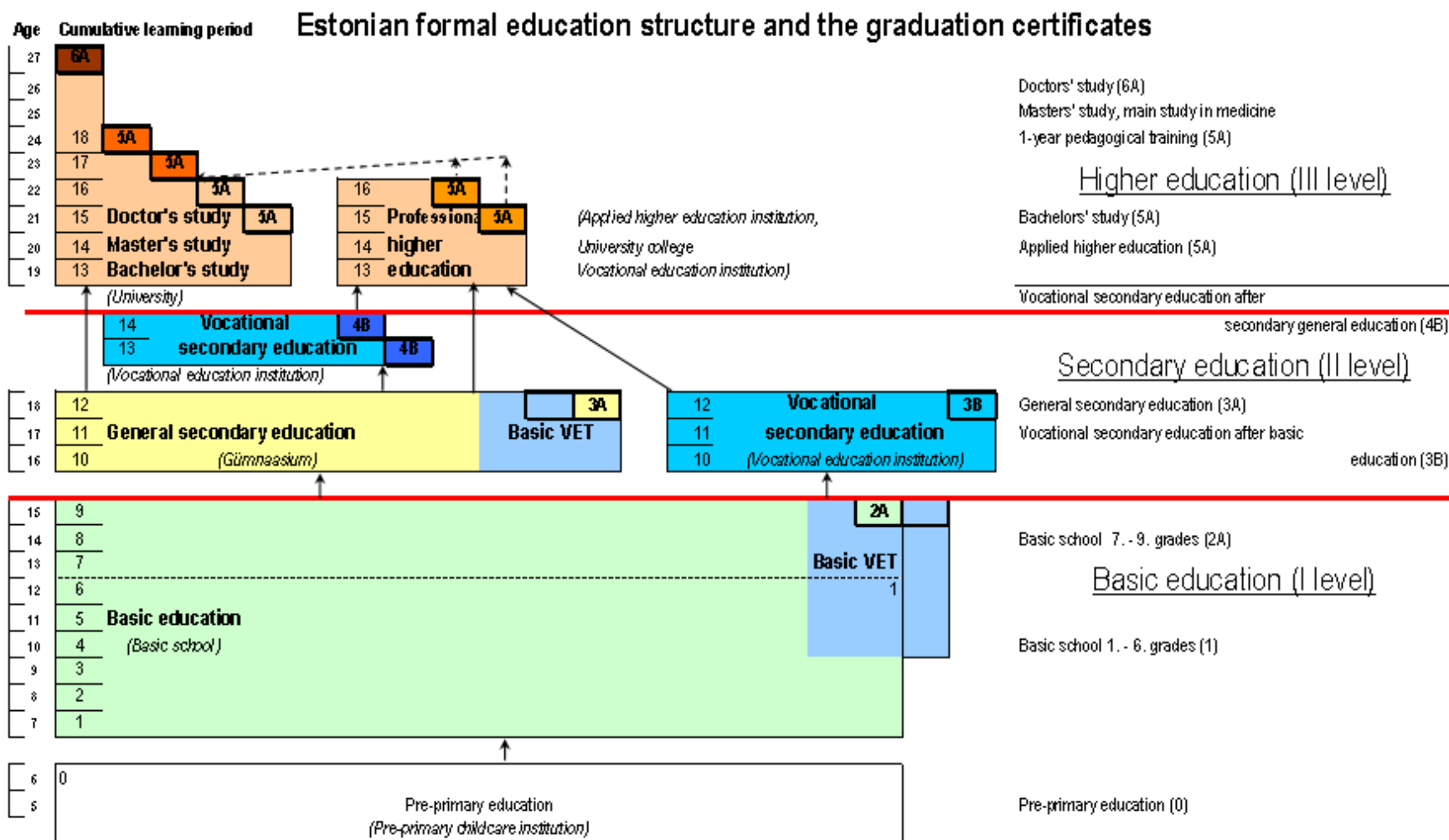

Figure A2.1. Structure of formal education system in Estonia.

Basic Schools and Upper Secondary Schools Act specifies that basic school is a school which provides students with opportunities to acquire basic education and fulfil the obligation to attend school. Basic schools are comprehensive schools. The aim of basic schools is to ensure the cognitive, moral, physical and social development of students and development of an integral world picture according to their age and to establish a study environment that is fit for the age of the students, secure, positive and enhancing development for the students. The broader principle foresees for accounting for the special needs and abilities of a student both in case the requirements of the curriculum are above the capacity of the student and in case the same requirements are too modest.

Educational activities in school may also be subject to the curriculum of the International Baccalaureate Organization and a curriculum based on the Convention Defining the Statute of the European Schools.

The objective of an upper secondary school is to ensure that students would find an area of activity that is in compliance with their interests and abilities to link their future educational path in an institution of higher education or vocational training based on upper secondary school.

A special feature in Estonia is the large number of Russian and bilingual (Estonian and Russian) schools. In the sense of organisation of studies, their activity is regulated by the same laws that regulate the Estonian-speaking schools. The learning objectives, aspirations and LOs are the same. The only difference is learning Estonian as a second language in schools that have Russian as the language of instruction. In 2007 transition to teaching of subjects in Estonian in the upper secondary school level was launched, meaning that all students who commence in form 10 must study at least 60% of the subjects in Estonian starting from 2011. Much emphasis has also been put on language immersion during the last ten years. According to the general principle the study volume depends on the level of the student – the higher the level the larger the volume of subjects in Estonian.

Pursuant to the ownership the schools are divided into municipal, private and state schools. The majority of schools in Estonia are municipal schools. State schools have been mainly established for students with special needs, e.g. for children with various disabilities, various interests etc.

Regardless of its form of ownership the school is guided in its activities by the respective national curriculum. It is recommended that in the basic school the content and level of studies be as uniform as possible. Starting from the year 2011 upper secondary schools have more liberty at developing their speciality than earlier as approximately 2/3 of their basic courses are fixed in the national curriculum and 1/3 are optional.

As of March 2015 there were 549 schools in Estonia, in 474 schools the language of instruction is Estonian, 66 are bilingual and in 30 the language of instruction is Russian. 495 are ordinary schools, 38 are for children with special needs and 16 are adult upper secondary schools.

A2.3. Vocational Education and Training

Acquisition of VET is governed by the **VET Institutions Act**.

Instruction in a VET institution is provided in the form of school-based or workplace-based study (apprenticeship). In case of school-based study work practice in an enterprise or institution shall not exceed one half of the total volume of the vocational training part of the curriculum. In case of workplace-based study work practice in an enterprise or institution shall constitute at least two thirds of the total volume of the programme. The rules and procedure for workplace-based study are established by a regulation of the MoER.

Studies in a VET institution take place in the form of auditory work, practical work, field training and independent work. Auditory work is offered in the form of lectures, seminars, lessons or any other form specified by the school. Practical work is the application of the acquired knowledge and skills in the study environment. Practical work takes place in the form of practical lessons, training lessons, laboratory work or other forms established by the school. Practical training is practical work with specific study goals which is carried out within the framework of a programme in a working environment (in an enterprise or institution) under the instruction of a supervisor. Independent work is the independent activity of a student for achieving LOs. Independent work shall make up at least 10 % of the entire volume of studies.

Practical work and practical training shall make up at least 50 % of the volume of the programme and their volumes are equal as a rule. Practical training in an enterprise or institution shall form a part of the programme and in order to conduct the practical training, a tripartite agreement is signed between the school, the student and the enterprise or institution of practical training before the start of the practical training. The school must ensure the student with a possibility of practical training as well as preparation, supervision and assessment of the practical training.

The assessment of the LOs of the students in the VET institutions is governed by the regulation of the MoER "Uniform assessment system applied in VET" (<https://www.riigiteataja.ee/akt/102072013001?leiaKehtiv>). The knowledge, skills and experience of students shall be evaluated on a five-point grading scale similar to the basic school and upper secondary school. The LO is considered achieved in case it has been evaluated from 3 («satisfactory») to 5 («very good»). Non-differentiated assessment of a subject, module or parts thereof is possible whereby the positive result is defined as "Pass" the negative result as "Fail".

For transferring a student of a VET institution from one study year to another he or she must have passed the courses studies prescribed by the curriculum for that programme. Transfer to the next study year is based on the decision of the Pedagogical Council of VET institution that can transfer the student conditionally, i.e. with academic debts while a term is prescribed for liquidation thereof.

Students who have interrupted their studies in a school have the right, under the conditions established by a regulation of the MoER, to continue studies at an upper secondary school in order to acquire upper secondary general education provided there are vacancies in the upper secondary schools. A student in a VET institution has the right to use part-time studies. Upon an agreement with the school the programme is completed within a period exceeding the nominal time.

Most of the VET institutions provide education on the basis of basic and upper secondary education, while in some institutions initial VET is provided for persons beyond the minimum school-leaving age, who lack basic education. Three VET institutions also offer professional higher education by way of an exception. VET on the basis of secondary education can be also obtained in eight institutions of professional higher education (.). In cooperation of numerous VET institutions and schools of general education preliminary VET is provided to the pupils in basic and upper secondary schools.

As of March 2015 there were 40 VET institutions in Estonia. Most of the institutions are state-owned (29). Besides state-owned VET institutions there are also 3 municipal VET institutions and 8 private VET institutions (<https://www.hm.ee/et/eesmargid-tegevused/kutseharidus>).

A2.4. Higher education

The general legal bases of higher education are „Republic of Estonia Education Act”, „Universities Act”, „Institutions of Professional Higher Education Act”, „Private Schools Act”, „Vocational Educational

Institutions Act” and „Standard of Higher Education”. The Structure of the higher education in Estonia is presented in Figure A2.2.

Universities provide Bachelor’s, Master’s and Doctoral programmes, but may also offer professional higher education. Professional higher education institutions and some vocational education institutions offer professional higher education programmes. A professional higher education institution may independently provide Master’s programmes in the fields of theology, internal defence and national defence. Master’s programmes in other fields of study may be provided in collaboration with a university. As to the form of ownership, higher education institutions may be state, public and private.

Student workload is measured in credits since the beginning of 1990s. Effective from the 2009/2010 academic year the European Credit Transfer and Accumulation System (ECTS) has officially been in use. One ECTS credit corresponds to 26 hours of student work. The workload of one academic year is 1560 hours or 60 ECTS credits.

In the credit system valid until the 2009/2010 academic year, one credit (*ainepunkt*, AP) corresponded to a workload of one week or 40 hours. The workload of one academic year was 40 AP that corresponds to 60 ECTS credits.

Professional Higher Education Programmes

Professional higher education is higher education of the first cycle, the purpose of which is to acquire the competences necessary for working in a certain profession or for continuing studies at the Master’s level. The nominal period of study is 3 to 4 years (180–240 ECTS). Midwifery studies and specialized nursing studies last 4.5 years (270 ECTS). The qualification awarded upon completion of the programme is *Rakendus kõrgharidusõppe diplom* (Professional Higher Education Diploma). The qualification gives access to Master’s programmes. Professional higher education studies have been developed from higher vocational education studies and diploma studies that were valid until the academic year of 2002/2003. The nominal length of both studies was 3 to 4 years and the qualification awarded to graduates is considered equal to professional higher education.

Bachelor’s Programmes

Bachelor’s programmes are first-cycle higher education programmes. The purpose of Bachelor studies is to broaden the scope of general education, to develop the basic knowledge and skills required for a certain field of study necessary for continuing at the Master’s level or for access to the labour market. The nominal duration of the programmes is generally 3 years (180 ECTS), as an exception, it may be up to 4 years (240 ECTS). Graduates who have completed their studies are awarded a degree which is certified by a diploma (on a greenish yellow form, marked with L). The qualification gives access to Master’s programmes.

Master’s Programmes

Master’s programmes are second-cycle higher education programmes. The purpose of Master’s level studies is to develop the knowledge and skills required for a certain field of study and to acquire the necessary competences in order to enter the labour market or to continue studies at the Doctoral level. The access requirement is a first-cycle higher education qualification. The nominal duration of the programmes is 1 to 2 years (60–120 ECTS), but together with the first-cycle studies it is at least 5 years (300 ECTS).

On completion of study programmes entered into the ECTS before 01.06.2002, the qualification *magistrikraad* is awarded as a research or professional degree. In the research degree programme, research comprises at least 50% of the studies and the final thesis involves a novel scientific approach to a problem within the respective field of study. In the professional degree programme, research,

development or creative work comprises at least 25% of the studies which are aimed at finding a novel solution to a creative professional problem. Under the conditions and pursuant to the procedures established by the university, successful completion of the programme entered into the EHIS before 01.06.2002 may be recognized as part of Doctoral studies.

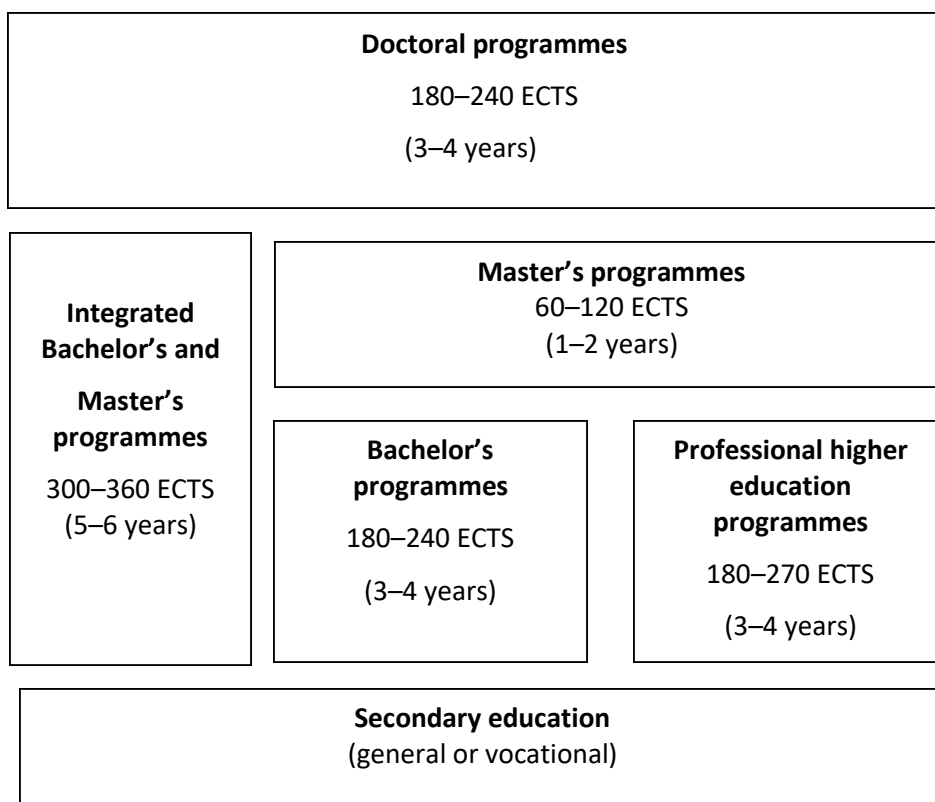

Figure A2.2. Structure of the higher education in Estonia

The qualification awarded upon completion of a Master's degree programme is *magistrikraad*. The qualification gives access to Doctoral programmes.

Integrated Bachelor's and Master's Programmes (equivalent to Master's degree)

Integrated Bachelor's and Master's programmes comprise both basic and specialized studies. Such long-cycle programmes are offered in the fields of medicine, dentistry, pharmacy, veterinary medicine, architecture, civil engineering, and class-teacher training. The nominal duration of medical studies and of veterinary medicine studies is 6 years (360 ECTS). The nominal duration of other integrated programmes is 5 years (300 ECTS).

The qualification awarded upon completion of an integrated study programme in the fields of pharmacy, architecture, civil engineering, and class-teacher training is *magistrikraad*, the other qualifications are *arstikraad* (in medicine), *hambaarstikraad* (in dentistry) and *loomaarstikraad* (in veterinary medicine). The qualifications give access to Doctoral programmes.

Doctoral Programmes

Doctoral programmes represent higher education of the third cycle, the purpose of which is to acquire knowledge and skills necessary for independent research, development or professional creative work. The access requirement for Doctoral studies is a *magistrikraad* or a corresponding qualification. The nominal period of study is 3 to 4 years (180–240 ECTS). The qualification awarded upon completion of Doctoral

studies is *doktorikraad*. *Doktorikraad* is a research degree obtained after the completion and public defence of a dissertation (*doktoritöö*) based on independent scientific research or creative work.

Regarding recognition of foreign qualifications, the comparison of inputs has been gradually replaced by LOs based evaluation. The study objectives and LOs achieved as well as rights granted in the country where it was awarded are more important than the content, volume of the curriculum and the proportion of theory and practical training.

A.2.5. Estonian Education Information System

In Estonia the current statistical data of education is electronically accumulated by the EHS (www.ehis.ee) operating on the basis of the regulation of the Government of the Republic "Establishment and Statutes of the Estonian Education Information System" (<https://www.riigiteataja.ee/akt/13357483?leiaKehtiv>). The data maintained in EHS are used by the students, educational institutions, local governments, ministries, government agencies etc.

EHS contains the following sub-registers:

- 1) sub-register of qualifications (certificates and diplomas);
- 2) sub-register of teachers and teaching staff;
- 3) sub-register of pupils, students and resident physicians;
- 4) sub-register of educational institutions;
- 5) sub-register of study programmes and licences.

Data in individual format contained in EHS are mostly used for passing various financing decisions. Statistical data serve as a basis for analyses and reports.

The access right to the data contained in the **sub-register of qualifications** is granted to a person entered in the register regarding data on him or her and all persons for the performance of tasks prescribed by law or international treaties. The objective of maintaining the sub-register is recording of national graduation documents and attesting the qualification of the persons owning these documents. The data of the sub-register have legal effect.

The following information shall be entered in the sub-register of qualifications:

- 1) the name of the educational institution or institutions having awarded the graduation document;
- 2) registration code or registration codes of the educational institution or institutions having awarded the graduation document or, upon the absence thereof the registry code of the manager of the educational institution or registry codes of the managers of the educational institutions;
- 3) type and code of the graduation document;
- 4) the given name and surname and ID code (in the absence thereof the date of birth) of the person;
- 5) series and number of the blank of the graduation document;
- 6) name and code of curriculum;
- 7) the range of numbers or a number of the certificate or diploma supplement;
- 8) graduation of an educational institution with honours;
- 9) the place and date of issue of the graduation document;
- 10) the number of the duplicate of the graduation document;
- 11) the date and bases for the issue of the duplicate of the graduation document.

Annex 3. Estonian occupational qualifications system

A3.1. Legal framework of the occupational qualifications system

The occupational qualifications system forms a part of the Estonian qualification system that links life- long learning system with the labour market (see Figure A3.1). The objective of the occupational qualifications system is

- to support the competitive edge of the Estonian workforce - Estonian workforce is competent, they have the knowledge, skills and attitudes required for successful operation;
- to form prerequisites that the content and quantity of studies targeted at occupational activities meet requirements of the labour market;
- to facilitate that the competence of individuals is appreciated and recognised, regardless where and how the studies took place;
- to make occupational qualifications internationally comparable.

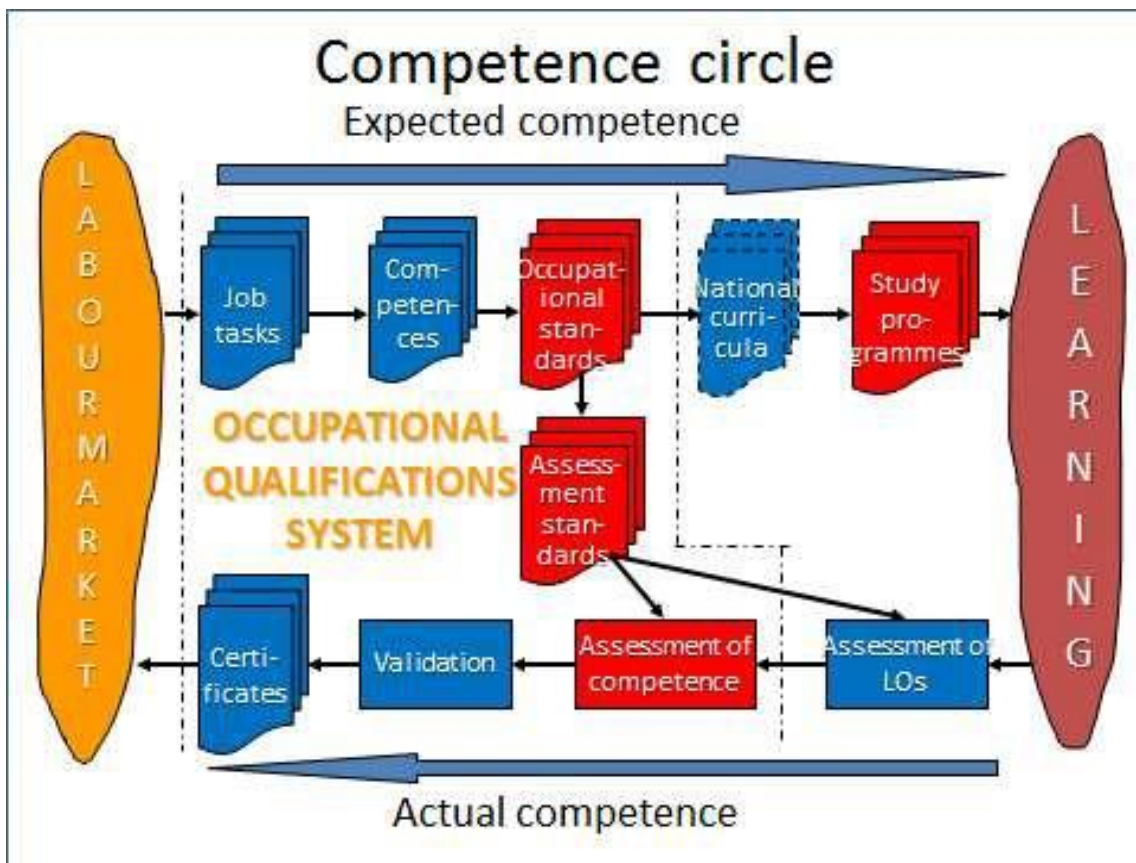

Figure A3.1. Conceptual scheme of the occupational qualifications system

The following principles have been taken into account while developing the occupational qualifications system in Estonia:

- Stakeholders of the labour market are involved in all parts of the occupational qualifications system: employers, employees, the state, trainers. Agreements are based on the co-operation of various stakeholders;
- The main concept of the occupational qualifications system is competence, that means the system is based on competence both conceptually and in reality;

Occupational qualifications system is built and operational as a quality system. The OQS consists of:

- System of occupational qualification standards;
- System for awarding occupational qualifications ;
- The system for the classification and cataloguing of occupational qualifications.

A3.2. Institutions of the occupational qualifications system

Institutions of the occupational qualifications system are:

- Ministry of Education and Research (MoER),
- Estonian Qualifications Authority (EstQA),
- Board of Chairmen of Sector Skills Councils (BCSSC),
- Sector Skills Council (SSC),
- Institution Awarding Occupational Qualifications (IAOQ),
- Occupational Qualifications Committee (OQC),
- Assessment Committee (AC).

Ministry of Education and Research is responsible for the development of an integral and structured occupational qualifications system. In order to perform these functions, the MoER has entered into a contract in public law with the EstQA.

Estonian Qualifications Authority is foundation in private law organising the development of the occupational qualifications system. The task of the EstQA is the organization and coordination of the activities of BCSSC and SSCs; development and approval of document forms and examples related to standards (OQSs); arranging development of OQSs and occupational qualifications system certificates, technical organisation of the awarding of occupational qualifications certificates, supervision of the activities of IAOQ, maintaining register of occupational qualifications, arranging the work of Europass centre, acting as the NCP for implementation of the EQF, counselling and training in regard of occupational qualifications system.

The EstQA was established in August 2001 by the Estonian Chamber of Commerce and Industry, Estonian Employers' Confederation, Ministry of Social Affairs, Estonian Employees' Unions' Confederation (TALO) and the Confederation of Estonian Trade Unions. In addition to the founders the Supervisory Board of the EstQA includes a representative of the MoER.

Board of Chairmen of Sector Skills Councils is a cooperation body consisting of the chairmen of SSC; operating at the EstQA; coordinates the cooperation between the SSCs, decides on the allocation of the initial occupational qualifications in the EstQF and the need to develop higher qualification levels, and approves the need for the development of the OQSs.

Sector Skills Council is an administrative body of the employees of the field of occupational activities, employers, representatives of professional associations and the state established by the Government of the Republic; develops OQSs in the area of own occupational activities; submits proposals for development of OQSs and approves the OQSs; grants the IAOQ the rights to award occupational qualifications and exercises supervision over their activities; approves the procedure for awarding occupational qualifications and the amount of fee thereof.

Institution awarding occupational qualifications is a legal person or its agency or government agency who

has been granted the right to award occupational qualifications as a result of a public competition; is responsible for the quality of the procedures of awarding of occupational qualifications; issues occupational qualification certificates.

Institution awarding initial occupational qualifications is an educational institution or training provider who has been granted the right to award initial occupational qualifications (entry level or levels into the occupation) in case the study programme meets the requirements of the OQS and has been nationally recognised or in case the studies are provided regarding a profession governed by the EU Directive 2005/36/EU the study programme meets the requirements of this directive; the name of the profession and the EstQF level is recorded on the diploma supplement issued by the IAPQ. The awarding of the initial occupational qualification started in 2011.

Occupational qualifications committee is a committee established by the IAOQ to ensure impartiality of the awarding process, consisting of the parties interested in awarding occupational qualifications in the given field: specialists, employers, employees, trainers, representatives of professional associations and, if necessary, representatives of clients, as well as other interested parties; develops in cooperation with the IAOQ procedures related to the assessment of competence and awarding of occupational qualifications and respective documents; appoints the assessment committee if necessary; decides on the awarding or refusal to award an occupational qualification to the person.

Assessment Committee is set up for the assessment of the competence of the person applying for an occupational qualification; accepts the occupational qualification exam; prepares records for the arrangement and results of the assessment and submits it to the SSC.

A3.3. Occupational qualification standards

OQS consists of three parts. Part A of the standard (description of the occupation) provides an overview of the nature of work, major parts of work and tasks, necessary tools, work environment, incl. the specificities of work and describes the personal characteristics and skills enhancing occupational activities. This is a source of information for a person upon selection of an occupation and shaping his or her career path. This also contains useful information for the career advisers, labour market consultants, human resources managers and trainers.

The competence requirements presented in B part of the standard serve as a basis for the assessment of the applicant for the occupational qualification. These requirements are presented as descriptions of mandatory and optional competences. Competence is an ability to perform a specific part of work or a task together with the knowledge, skills and attitudes required for that. Proceeding from the nature of the occupation, its specificity and traditions, attesting competences related to a specialization or optional competences may be the prerequisite for being awarded the occupational qualification.

Part C of the standard contains general information and references to annexes. A sample OQS is presented in Annex 4.

OQS shall meet the following conditions:

- Is based on the job analysis or functional analysis;

- Describes expected competences as observable and assessable;
- Defines the method(s) for assessing of persons' competence;
- Defines the EstQF level of the respective occupational qualification.

The proposal regarding the need for developing or updating of OQS is made by the SSC based on the proposals of appropriate organisations or persons. A decision regarding development of OQS is passed by the BCSSC. The OQS is prepared by the working group established by the SSC. The working group includes the specialists of the respective field - employers, specialists and trainers. The EstQA organises the work of the working groups.

Development of the OQSs and their referencing to the EstQF takes place in the framework of European Social Fund (ESF) sponsored programme "Development of the occupational qualifications system 2008- 2013 ". The programme includes updating the form and methodology of developing occupational qualifications system. Based thereon, OQSs are updated, the methods for assessing competence are improved, *inter alia* an option is provided for awarding initial occupational qualification upon the completion of a VET or higher education institution. All new OQSs developed are LOs based.

A3.4. Sector skills councils

Sector skills council is a cooperative body between confederations of employers/employees of the respective field of occupational activity, professional associations and the authorised representatives of the ministries.

There are 14 sector skills councils formed by the Estonian Government:

- 1) Commercial Service and Other Business Activities;
- 2) Architecture, Geomatics, Construction and Real Estate;
- 3) Service;
- 4) Forestry;
- 5) Health
- 6) Social Care;
- 7) Engineering, manufacturing and processing
- 8) Food Industry and Agriculture;
- 9) Transport and Logistics;
- 10) Energy, Mining and Chemical Industry;
- 11) Information Technology and Telecommunication;
- 12) Property and Personal Protection
- 13) Culture;
- 14) Education.

The objective of the SSC is analysing suggestions of different institutions, and achieving a consensus upon developing OQSs and awarding occupational qualifications. The SSC shall appoint working groups in the field. These working groups shall map the field of occupational activity, develop the OQSs and schemes for awarding occupational qualifications.

A3.5. Institutions awarding occupational qualifications

An institution awarding occupational qualification:

- Develops in cooperation with the occupational qualifications committee (OQC) the draft rules and procedure for the awarding of occupational qualifications and submits it to the SSC while applying for the right to award occupational qualifications;
- Organises the development of the guidelines for the assessment of occupational competence, examination materials and other documents required for the awarding of occupational qualification;
- Calculates and submits to the SSC for approval the amount of the fee related to the awarding of the occupational qualification and re-attestation of the occupational qualification, approving it with the OQC in advance;
- Announces the awarding of the occupational qualification;
- Makes information related to the awarding of an occupational qualification publicly available;
- Checks the validity of the application and documents of the person applying for the occupational qualification and submits appropriate documents to the OQC for passing a decision;
- Issues the occupational qualification certificate or the duplicate thereof;
- Ensures the protection of the information not subject to disclosure obtained in the process of awarding an occupational qualification;
- Is responsible for the organisation of awarding occupational qualifications;
- At least once a year submits a report on the organisation of the awarding occupational qualifications to the SSC and the report regarding the use of funds related to the awarding of occupational qualifications.
- Forwards the data to be entered into the register of occupational qualifications to the EstQA.

IAOQ appoints a person responsible for the performance of the listed tasks.

In order to be granted the right to award occupational qualifications an open competition arranged by EstQA shall be completed. A legal person or authority that has been declared a winner by a decision of a SSC in a public competition and that has the corresponding registration in the register of occupational qualifications may act as an IAOQ.

Upon registration, the names and levels of occupational qualifications which the IAOQ shall be entitled to award will be determined. The procedure for the organisation of the competition and the list of documents certifying compliance with the conditions listed in §11 (1) the Occupational Qualifications Act has been established by a regulation of the MoER (<https://www.riigiteataja.ee/akt/13214816>).

§11 (1) of the Occupational Qualifications Act stipulates the following requirements:

- 1) the activities of an IAOQ include the development of relevant occupational activities;
- 2) the IAOQ must have the means and possibilities necessary to organise the awarding process;
- 3) the IAOQ is required to have hired a sufficient number of employees with the necessary qualification, and has to have set up a OQC (or OQCs);
- 4) the IAOQ must be able to act independently, professionally, impartially and without discriminating anyone.

In order to be granted the right of an awarding institution the organisation must prepare the rules and procedure for awarding the occupational qualifications and to set up an OQC.

The organisation having been granted the right to award occupational qualifications will be entered into the register of occupational qualifications (www.kutsekoda.ee). The organisation having won the competition is granted the right to award occupational qualifications for five years.

There are 105 IAOQ-s at the EstQA.

A3.6. Occupational qualifications committees

To ensure impartiality in awarding occupational qualifications, the IAOQ shall set up an OQC that shall consist of the parties interested in awarding occupational qualifications in the given field: specialists, employers, employees, trainers, representatives of professional associations and, if necessary, representatives of clients, as well as other interested parties.

Occupational qualifications committee shall:

- Prepare the rules and procedure for awarding occupational qualifications in cooperation with the IAOQ;
- Approve, if necessary, the requirements for the place of assessment of occupational competence;
- Check the documents of the applicant and decide on the form and manner for assessment of the occupational competence of the applicant;
- Appoint assessment committee(s) to assess the conformity of the applicant's competence with the requirements of the OQS;
- Approve the instructions for assessment and the examination materials;
- Decide on awarding or refusing to award occupational qualification to the applicant;
- Resolve the complaints submitted regarding the activities of the assessment committee;
- Perform other functions provided by law.

The rules and procedure for the awarding of occupational qualification describes general requirements for awarding occupational qualification and the procedure for the application and methods for assessing applicant's competence.

There are 200 occupational qualifications committees at the EstQA.

A3.6. Register of occupational qualifications

Register of occupational qualifications was established in 2001 with the objective to collect, systematise and maintain data regarding SSCs, OQSs, occupational qualification certificates, IAOQs, OQCs and procedures for awarding occupational qualifications.

The register shall be kept as a single-level computerised database in accordance with the Occupational Qualifications Act, the National Databases Act, Statutes for Maintenance of the Occupational Qualifications Register (<https://www.riigiteataja.ee/akt/13185447>), and other legislation.

The register comprises:

- 1) Current data set in digital format;
- 2) Register archive comprising data having lost their acuteness, data collected in regard of data processing and basic documents being the basis for entering data in the register.

The data entered into the register archive are preserved for ten years.

Annex 4. Description of sub-frameworks referenced to the EstQF

EstQF level	EstQF level description	General education framework	VET framework	Higher education framework	Occupational qualifications framework
Level 1	<p>The owner of EstQF level 1 qualification:</p> <p>Has basic general knowledge;</p> <p>Has basic skills required to carry out simple tasks;</p> <p>Works or studies under direct supervision in a structured content.</p>	<p>The graduate of study programme for students with moderate and severe learning disabilities:</p> <p>Characterises and compares objects/regions using different sources of information, gives examples of links between natural elements, between environment and human activities, provides information to fellow students;</p> <p>Distinguishes and names human organs based on a model/drawing and describes their functions;</p> <p>Knows and values the principles of a healthy lifestyle;</p> <p>Demonstrates basic first aid techniques in a learning situation;</p> <p>Describes and explains characteristics of learned phenomena and gives examples of their occurrence in everyday life;</p> <p>Describes the operation principles of simple household equipment, safely handles everyday household instrumentation;</p> <p>Gives examples of the usage of learned substances/materials in everyday life, understands the dangers of known chemicals and follows necessary safety requirements;</p> <p>Gives examples of the usage of electrical appliances in daily life,</p>			<p>The owner of EstQF level 1 occupational qualification:</p> <p>Owns basic work knowledge;</p> <p>Performs uncomplicated routine tasks observing set procedures and detailed guidelines;</p> <p>Uses appropriate tools;</p> <p>Works in a limited situation under a direct guidance;</p> <p>Is responsible for the performance of the duties.</p>

		explains their purpose and safety requirements; Understands the principles for environment sustainability, describes environment saving methods.			
Level 2	<p>The owner of EstQF level 2 qualification:</p> <p>Has basic factual knowledge of a field of work or study;</p> <p>Has basic cognitive and practical skills required to use relevant information in order to carry out tasks and to solve routine problems;</p> <p>Uses simple rules and tools;</p> <p>Works and studies under supervision with some autonomy.</p>	<p>The graduate of simplified study programme for basic school:</p> <p>Adequately communicates in everyday situations (listens to partner, asks questions, explains his positions, solves differences, admits his errors and misconduct); responds adequately to misbehaviour towards himself and others;</p> <p>Assesses the behaviour of himself and his peers in everyday situations in accordance to society norms, behaves accordingly;</p> <p>Knows the rules and norms of supportive relationships between humans, values compassion, honesty, justice and responsibility;</p> <p>Describes the conditions for the development of infants and toddlers and care methods;</p> <p>Understands the importance of basic human resources (time, knowledge/skills, work, money), is able to plan the activities relating to the replenishment/ consuming of these resources;</p> <p>Is able to request information from others, use informational texts and manuals;</p> <p>Describes housing acquisition, refurbishing and maintenance needs, opportunities, risks and liabilities;</p> <p>Adequately assesses his abilities, knowledge, skills, continuing education opportunities and conditions with guidance from a</p>	<p>The graduate of VET study programme without basic education requirement:</p> <p>Knows and describes the main concepts and principles of the occupation;</p> <p>Understands the main work processes, is familiar with the occupation specific terms, materials, tools and with commonly used equipment;</p> <p>Is able to fulfil simple occupation specific tasks with limited responsibility;</p> <p>Is able to perform the job tasks under the guidance;</p> <p>Is working efficiently in stable work situations;</p> <p>Is able to learn upon guidance and counselling;</p> <p>Is able to communicate in common situations and with familiar partners;</p> <p>Is able to use advice, help, support and provided information materials to solve occupation specific issues;</p> <p>Is able to evaluate the results of work upon counselling;</p> <p>Is able to adapt and cope in different social environments upon guidance;</p> <p>Has some knowledge about the possibilities offered by IT;</p> <p>Is able to use internet to certain extent;</p> <p>Is able to use some applications upon guidance;</p>		<p>The owner of EstQF level 2 occupational qualification:</p> <p>Owns basic work knowledge;</p> <p>Performs uncomplicated tasks observing set procedures and guidelines;</p> <p>Selects and uses appropriate tools and equipment;</p> <p>Works in a fixed situation with a certain degree of independence;</p> <p>Is responsible for the performance of the duties.</p>

		<p>counsellor and makes the most appropriate career choice; Knows his basic rights and obligations as an employee, can name ways to obtain help and information on issues related to labour law; Understands the risks and negative consequences of working without a contract and envelope salary; Recognizes signs of human trafficking on job search, is aware of the risks and can describe the correct behaviour when falling to victim of human trafficking.</p> <p>The graduate of basic education study programme:</p> <p>Is familiar with generally recognised values and moral norms, follows them, does not remain indifferent when they are disregarded, and shall interfere within his or her capabilities, when necessary;</p> <p>Knows and respects his or her mother tongue and culture and contributes to perseverance and development of the Estonian language and culture;</p> <p>Has an understanding and knowledge of different cultures of the world, regards people of other nations without prejudice and with respect;</p> <p>Is inquisitive, knows how to learn and find ways for further studies, using relevant advice, if necessary;</p> <p>Has initiative, believes in himself or herself, shapes his or her ideals, sets goals and works to achieve them, directs and corrects his or her</p>	<p>Is able to express the ideas and apply them upon guidance; Is able to make appropriate choices under guidance from provided opportunities, that are suitable to his or her skills; Takes part in his or her career planning.</p>		
--	--	----------------------------------------------------------------------------------------------------------------------------------------------------------------------------------------------------------------------------------------------------------------------------------------------------------------------------------------------------------------------------------------------------------------------------------------------------------------------------------------------------------------------------------------------------------------------------------------------------------------------------------------------------------------------------------------------------------------------------------------------------------------------------------------------------------------------------------------------------------------------------------------------------------------------------------------------------------------------------------------------------------------------------------------------------------------------------------------------------------------------------------------------------------------------------------------------------------------------------------------------------------------------------------------------------------------------------------------------------------------------------	---------------------------------------------------------------------------------------------------------------------------------------------------------------------------------------------------------------------------------------------------------------	--	--

		<p>behaviour and takes responsibility for his or her actions;</p> <p>Is able to express himself or herself clearly and adequately in speech and writing, regarding the situation and surrounding people; to understand and interpret different texts; knows and follows the rules of orthography;</p> <p>Speaks at least one foreign language at a level that enables to communicate in everyday situations in written and oral form, and to read and understand foreign texts fit for his or her age;</p> <p>Is able to solve issues arising in different spheres of everyday life that require the use of mathematical methods (equations, models, schemes, graphs);</p> <p>Understands the connections between humans and environment, is responsible towards the living environment and lives and acts in a way that saves nature and the environment;</p> <p>Knows how to ask questions of natural science, have a discussion on them, present scientific views and make deductions based on evidence;</p> <p>Is able to manage in the world of technology and to use technology purposefully and with as little risk as possible;</p> <p>Is an active and responsible citizen who is interested in the democratic development of his or her school, community and country;</p>			
--	--	--------------------------------------------------------------------------------------------------------------------------------------------------------------------------------------------------------------------------------------------------------------------------------------------------------------------------------------------------------------------------------------------------------------------------------------------------------------------------------------------------------------------------------------------------------------------------------------------------------------------------------------------------------------------------------------------------------------------------------------------------------------------------------------------------------------------------------------------------------------------------------------------------------------------------------------------------------------------------------------------------------------------------------------------------------------------------------------------------------------------------------------------------------------------------------------------------------------------------------------------------------------------------------------	--	--	--

		<p>Is able to express himself or herself creatively, respects art and cultural heritage;</p> <p>Values and practices a healthy lifestyle and is physically active;</p> <p>Thinks systematically, creatively and critically, is open to self-development.</p>			
Level 3	<p>The owner of EstQF level 3 qualification:</p> <p>Has knowledge of facts, principles, processes and general concepts, in a field of work or study;</p> <p>Has a range of cognitive and practical skills required to accomplish tasks and solve problems by selecting and applying basic methods, tools, materials and information;</p> <p>Takes responsibility for completion of tasks in work or study;</p> <p>Adapts own behaviour to circumstances in solving problems.</p>		<p>The graduate of VET study programme based on basic education:</p> <p>Knows occupation specific terminology, principles, technologies, processes, techniques, materials, tools, equipment, and is able to use and apply them;</p> <p>Is able to independently fulfil various occupation specific assignments;</p> <p>Is able to work independently and be responsible of the work results in stable or in slightly variable situations;</p> <p>Is responsible for his or her job performance;</p> <p>Is able to learn and self-develop independently;</p> <p>Is able to substantiate his or her opinions and express himself or herself in various situations both orally and in writing;</p> <p>Is able to use common sources of information to solve occupation specific issues;</p> <p>Is able to solve occupation specific issues in an optimal way and change his or her behaviour if necessary;</p> <p>Is participating effectively in different teams and is able to fulfil various roles within these teams;</p>		<p>The owner of EstQF level 3 occupational qualification:</p> <p>Understands basic facts and principles regarding work;</p> <p>Knows basic work techniques;</p> <p>Performs basic job tasks;</p> <p>Selects and uses tools and methods;</p> <p>Acts according to plans, in a sparing and effective manner;</p> <p>Works in a generally fixed situation independently;</p> <p>Organises his or her actions and adjusts it according to the situation;</p> <p>Participates in teamwork efficiently;</p>

			<p>Knows the main possibilities and potential threats of IT; Is able to use the main possibilities available on the internet both for personal and occupational purposes; Is able to use various resources and means to develop ideas and to implement them; Is able to express opinions about experiences, describe, present and evaluate his or her ideas and work; Is able to set career goals upon guidance; Is able to find information (incl. using electronic channels) about job vacancies upon guidance; Is able to associate the requirements of occupation specific training with the employability on the labour market upon guidance.</p>		<p>Is responsible for the performance of the duties.</p>
Level 4	<p>The owner of EstQF level 4 qualification:</p> <p>Has factual and theoretical knowledge in broad contexts within a field of work or study;</p> <p>Has a range of cognitive and practical skills required to generate solutions to specific problems in a field of work or study;</p> <p>Exercises self-management within the guidelines of work or study</p>	<p>The graduate of upper secondary school curriculum:</p> <p>Conducts in an ethical manner, follows the generally accepted values and moral norms;</p> <p>Takes responsibility for his or her choices and obligations taken, respects other people's and one's own freedom, is a sovereign personality;</p> <p>Uses different learning strategies, is able to compile a research and to present it, is able to work in a team and make a contribution to achieving collective goals;</p> <p>Knowingly helps to preserve and develop the Estonian language, culture and country; understands the Estonian culture in the context of European and other cultures;</p>	<p>The graduate of the fourth level VET curriculum:</p> <p>Has in-depth knowledge of the occupation, incl. knowledge how to implement principles, theories and technologies of the vocation both in common and new work situations; Is able to independently fulfil complex and variable assignments of the occupation that require innovative solutions;</p> <p>Is responsible for fulfilling his or her work assignments;</p> <p>Uses initiative to learn and self-develop independently;</p> <p>Is able to evaluate and analyse his or her level of knowledge; Is able to substantiate his or her opinions in detail and express them</p>		<p>The owner of EstQF level 4 occupational qualification:</p> <p>Interprets and integrates extensive work-related knowledge and uses them in new situations;</p> <p>Performs basic tasks;</p> <p>If necessary, initiates, prepares and adjusts appropriate changes;</p> <p>Acts and organises work according to plans, in a sparing</p>

	<p>contexts that are usually predictable, but are subject to change;</p> <p>Supervises the routine work of others, taking some responsibility for the evaluation and improvement of work or study activities.</p>	<p>understands, values and respects his or her cultural traditions, as well as the ones of other nations;</p> <p>Is able to evaluate his or her aspirations while taking into consideration his or her abilities and possibilities; is able to foresee possible success and failure; is aware of different fields of work and directions of the labour market; is able to obtain information on further studies and job opportunities; plans his or her career;</p> <p>Uses language correctly and expressively, is able to debate in a reasoned manner;</p> <p>Thinks critically and creatively, develops and values his/her ideas and the ones of others, can justify his or her choices and views;</p> <p>Can speak at least two foreign languages at the level of an independent language user;</p> <p>Uses mathematical knowledge and methods in different spheres of life;</p> <p>Has a developed scientific view of the world and understands the essence of modern natural sciences; is familiar with global issues and takes personal responsibility for helping to solve them; values and follows the principles of sustainable development;</p> <p>Uses modern technology purposefully and with a sense of responsibility, values the impact of technology on everyday life, has</p>	<p>also in new situations both orally and in writing;</p> <p>Is able to use specific sources of information to solve occupation specific issues, evaluate the reliability and validity of the information used;</p> <p>Is able to use self-evaluation to change his or her behaviour;</p> <p>Is able to make suggestions to improve the work results;</p> <p>Is able to participate effectively in various teams and lead them if necessary;</p> <p>Is partially able to guide co-workers;</p> <p>Knows the role, possibilities and potential threats of IT;</p> <p>Is able to critically evaluate the reliability of available information;</p> <p>Is able to use the main application programmes and possibilities of the internet both for personal and occupational purposes;</p> <p>Is able to create, present and understand information using software tools and use internet-based search systems and other services;</p> <p>Is able to think systematically and creatively, critically evaluate and find possibilities to implement his or her ideas;</p> <p>Is able to initiate, develop and implement ideas;</p> <p>Has primary knowledge about entrepreneurship;</p> <p>Is able to compile his or her short- and long-term career plan upon guidance;</p> <p>Is able to independently find opportunities for occupation specific</p>		<p>and effective manner;</p> <p>Selects and uses tools and methods for performing common and novel tasks;</p> <p>Works independently in situations what can be usually foreseen but that can also change;</p> <p>Supervises common work made by others and takes some responsibility for the development of others.</p>
--	-------------------------------------------------------------------------------------------------------------------------------------------------------------------------------------------------------------------	-------------------------------------------------------------------------------------------------------------------------------------------------------------------------------------------------------------------------------------------------------------------------------------------------------------------------------------------------------------------------------------------------------------------------------------------------------------------------------------------------------------------------------------------------------------------------------------------------------------------------------------------------------------------------------------------------------------------------------------------------------------------------------------------------------------------------------------------------------------------------------------------------------------------------------------------------------------------------------------------------------------------------------------------------------------------------------------------------------------------------------------------------------------------------------------------------------------------------------------------------------------------------------------------------	--------------------------------------------------------------------------------------------------------------------------------------------------------------------------------------------------------------------------------------------------------------------------------------------------------------------------------------------------------------------------------------------------------------------------------------------------------------------------------------------------------------------------------------------------------------------------------------------------------------------------------------------------------------------------------------------------------------------------------------------------------------------------------------------------------------------------------------------------------------------------------------------------------------------------------------------------------------------------------------------------------------------------------------------------------------------------------------------------------------------------------------------------------------------------------------------------------------------------------------------------------------------------------------------------------------------------------------------------	--	-------------------------------------------------------------------------------------------------------------------------------------------------------------------------------------------------------------------------------------------------------------------------------------------------------------------------

		<p>conscious views on development of technology and its use;</p> <p>Has developed and active position as a citizen, sees himself or herself as a dialogue competent member of society in the contexts of Estonia, Europe and the world; is able to avoid and solve conflicts, is tolerant;</p> <p>Appreciates fine arts, is able to use tools in his or her creations, as well as techniques and materials;</p> <p>Practices a healthy lifestyle, knows how to preserve and restore his or her mental and physical health.</p>	<p>self-development and it's application on the labour market;</p> <p>Is able to associate the requirements of occupation specific training with the employability on the labour market.</p> <p>The graduate of upper secondary VET study programme or VET study programme based on upper secondary education:</p> <p>Has in-depth knowledge of his or her occupation, including knowledge how to implement occupation specific principles, theories, technologies both in common and new work situations;</p> <p>Associates occupation specific knowledge with scientific methods and with the basic principles and processes of natural sciences and mathematics;</p> <p>Understands the development of scientific theories, applications and technologies and the associated risks, values security and sustainable development;</p> <p>Is able to independently fulfil complex and variable occupation specific assignments requiring innovative solutions;</p> <p>Is responsible for fulfilling his or her work assignments;</p> <p>Is able to use mathematical knowledge and methods in different life situations;</p> <p>Is able to express himself or herself, present and substantiate his or her opinions both orally and in writing in</p>		
--	--	--------------------------------------------------------------------------------------------------------------------------------------------------------------------------------------------------------------------------------------------------------------------------------------------------------------------------------------------------------------------------------------------------------------------------------------------------------------------------------------------------------------------------------	--------------------------------------------------------------------------------------------------------------------------------------------------------------------------------------------------------------------------------------------------------------------------------------------------------------------------------------------------------------------------------------------------------------------------------------------------------------------------------------------------------------------------------------------------------------------------------------------------------------------------------------------------------------------------------------------------------------------------------------------------------------------------------------------------------------------------------------------------------------------------------------------------------------------------------------------------------------------------------------------------------------------------------------------------------------------------------------------------------------------------------------------------------------------------------------------------------------------------------------------------------------	--	--

			<p>a native language and in a foreign language on a level of independent language user, taking into consideration the communication situations and partners;</p> <p>Uses initiative to learn and self-develop independently;</p> <p>Is able to evaluate and analyse his or her level of knowledge and skills, where necessary seeks for advice, information and support;</p> <p>Is able to use his or her knowledge, incl. learning skills and strategies in different contexts and in solving problems;</p> <p>Is able to value the search for justifications and is able to evaluate their validity;</p> <p>Is able to substantiate his or her opinions in detail and express them in new situations both orally and in writing;</p> <p>Is able to use various and specific sources of information to solve occupation specific issues, search, collect and process information and evaluate the reliability and validity of the information used;</p> <p>Is able to formulate and express his or her oral and written arguments convincingly and in context;</p> <p>Is able to use self-evaluation to change his or her behaviour;</p> <p>Is able to make suggestions to improve the work results;</p> <p>Is able to perceive and value connectivity with his or her cultural heritage and with the cultural heritage of other nations, and with the events of modern culture;</p>		
--	--	--	---------------------------------------------------------------------------------------------------------------------------------------------------------------------------------------------------------------------------------------------------------------------------------------------------------------------------------------------------------------------------------------------------------------------------------------------------------------------------------------------------------------------------------------------------------------------------------------------------------------------------------------------------------------------------------------------------------------------------------------------------------------------------------------------------------------------------------------------------------------------------------------------------------------------------------------------------------------------------------------------------------------------------------------------------------------------------------------------------------------------------------------------------------------------------------------------------------------------------------------------------------------------------------------------------------------------------------------------------------------------------------------	--	--

			<p>Is able to value and enjoy the creativity and express himself or herself creatively;</p> <p>Values correct and expressive language;</p> <p>Knows and values a healthy lifestyle, is able to maintain and if necessary, how to restore his or her mental and physical fitness;</p> <p>Is able to realise himself or herself, act as an informed and responsible citizen and as a member of the society with the ability for dialogue, behave tolerantly;</p> <p>Is able to participate effectively in different teams and lead them if necessary;</p> <p>Is able to partly guide co-workers;</p> <p>Is able to use technological tools and scientific data to achieve his or her objectives or to make a decision or a conclusion;</p> <p>Knows the role, possibilities and potential threats of the IT;</p> <p>Is able to critically evaluate the reliability of the available information;</p> <p>Is able to use the main software applications and possibilities of the internet both for personal and occupational purposes;</p> <p>Is able to create, understand and present information in correct language using software tools, use internet-based search systems and other services;</p> <p>Is able to think systematically and creatively and critically evaluate his or her own ideas and independently find possibilities to implement them;</p> <p>Is able to initiate, develop and implement ideas;</p>		
--	--	--	-------------------------------------------------------------------------------------------------------------------------------------------------------------------------------------------------------------------------------------------------------------------------------------------------------------------------------------------------------------------------------------------------------------------------------------------------------------------------------------------------------------------------------------------------------------------------------------------------------------------------------------------------------------------------------------------------------------------------------------------------------------------------------------------------------------------------------------------------------------------------------------------------------------------------------------------------------------------------------------------------------------------------------------------------------------------------------------------------------------------------------------------------------------------------------------------------------------------------------------------------------------------------------------------------------------------------------------------------------------------------------------------------------------------------	--	--

			<p>Has primary knowledge about entrepreneurship;</p> <p>Is able to compile his or her own short- and long-term career plan upon guidance;</p> <p>Is able to independently find opportunities for occupation specific self-development and it's application on the labour market;</p> <p>Is able to associate the requirements of occupation specific training with the employability on the labour market.</p>		
Level 5	<p>The owner of EstQF level 5 qualification:</p> <p>Has specialised, factual and theoretical knowledge within a field of work or study and an awareness of the boundaries of that knowledge;</p> <p>Has a comprehensive range of cognitive and practical skills required to develop creative solutions to abstract problems;</p> <p>Exercises management and supervision in contexts of work or study activities where there is unpredictable change; Reviews and</p>		<p>Has in-depth knowledge of his or her vocation, occupation, incl. knowledge how to creatively implement occupation specific principles, theories and technologies both in common and new work situations;</p> <p>Is able to independently fulfil complex and variable work assignments of his or her occupation requiring creative and innovative solutions;</p> <p>Is able to select and use appropriate methods for fulfil the work assignments and problem solving;</p> <p>Is responsible for fulfilling his or her work assignments;</p> <p>Uses initiative to learn and self-develop independently, is able to evaluate his or her learning, determine the need for self-development and continuation of studies;</p> <p>Is able to evaluate and analyse his or her level of knowledge;</p> <p>Is able to substantiate his or her opinions in detail and express them in new situations and communicate his or her thoughts and intentions</p>		<p>The owner of EstQF level 5 occupational qualification:</p> <p>Analyses information and approaches;</p> <p>Uses knowledge for creative solving of abstract tasks within limits of interconnected areas;</p> <p>Performs diverse tasks, plans appropriate changes and organises application thereof;</p> <p>Selects and applies technologies, methods and tools for obtaining new solutions and adjusts his or her behaviour according to the situation;</p>

	<p>develops performance of self and others.</p>		<p>clearly and understandably, both orally and in writing; Is able to use different and specific sources of information to solve occupation specific issues; Is able to evaluate the reliability and validity of the information used; Is able to use self-evaluation to change his or her behaviour, taking into consideration the social context where necessary; Is able to adequately evaluate his or her work, make suggestions to improve the work results and guide to the co-workers in variable situations;</p> <p>Is able to guide co-workers and is able to be partly responsible for their training; Is participating effectively in the work of various teams and is able to put teams together and lead them when necessary; Knows the information- and communication technologies necessary for the job; Is able to critically evaluate the reliability and validity of the available information; Is able to use the main software applications and possibilities of the internet both for personal and occupational purposes; Is able to create, present and understand information using software tools, internet-based search systems and other services; Is able to find and analyse relevant information to implement the ideas and evaluate the reliability of the source or the approach;</p>		<p>Works independently in unpredictable situations; Takes responsibility for a small workgroup.</p>
--	-------------------------------------------------	--	--------------------------------------------------------------------------------------------------------------------------------------------------------------------------------------------------------------------------------------------------------------------------------------------------------------------------------------------------------------------------------------------------------------------------------------------------------------------------------------------------------------------------------------------------------------------------------------------------------------------------------------------------------------------------------------------------------------------------------------------------------------------------------------------------------------------------------------------------------------------------------------------------------------------------------------------------------------------------------------------------------------------------------------------------------------------------------------------------------------------------------------------------------------------------------------------------------------------------------------------------------------------------------------------------------------------------------------------------------------------------------------------------------------------------------------------------------	--	------------------------------------------------------------------------------------------------------------------

			<p>Is able to present and defend his or her viewpoints and ideas in personal, public and official communication, take decisions and experiment;</p> <p>Is able to compile a business plan;</p> <p>Is able to independently compile short and long-term career plans for himself or herself;</p> <p>Is able to analyse and evaluate independently his or her occupation specific training and it's applicability on the labour market, and possibilities to continue studies.</p>		
Level 6	<p>The owner of EstQF level 6 qualification:</p> <p>Has advanced knowledge of a field of work or study, involving a critical understanding of theories and principles;</p> <p>Has advanced skills, demonstrating mastery and innovation, required to solve complex and unpredictable problems in a specialised field of work or study;</p> <p>Manages complex technical or professional activities or projects, taking responsibility for decision-making in unpredictable</p>			<p>The graduate of professional higher education study programme:</p> <p>Has a systematic overview of the basic concepts, theoretical principles and research methods of the speciality;</p> <p>Recognise current problems and implementation possibilities of the speciality;</p> <p>Is able to identify interdisciplinary connections in the scope of application of different specialties;</p> <p>Is able to formulate problems relating to the speciality and analyse and evaluate different solutions;</p> <p>Is able to gather information independently by using appropriate methods and means and to interpret it critically and creatively;</p> <p>Is able to select and use appropriate technologies and methods when solving problems of the speciality within given frameworks, and to</p>	<p>The owner of EstQF level 6 occupational qualification:</p> <p>Analyses and assesses facts, theories, principles and methods;</p> <p>Uses knowledge for creative solving of abstract tasks in interconnected areas;</p> <p>Performs complicated tasks assuming novel approach and excellence;</p> <p>Intertwines activities and methods and assesses their potential results;</p> <p>Makes decisions on the basis of partial information;</p>

	<p>work or study contexts;</p> <p>Takes responsibility for managing professional development of individuals and groups.</p>			<p>model and/or assess the potential results on the basis of the information given;</p> <p>Shows initiative in the launching of projects and responsibility, leadership and teamwork skills in implementation thereof;</p> <p>Has command of the communication skills and information and communication technologies necessary for work;</p> <p>Is able to explain orally or in written form in the language of instruction and at least one foreign language problems relating to the speciality, and to participate in professional discussions;</p> <p>Is willing to actively participate in civil society and demonstrate tolerance towards the diversity of attitudes and values;</p> <p>Is able to evaluate the role and consequences of professional activities for the scientific community, with consideration to social and ethical aspects;</p> <p>Is able to evaluate the role and consequences of professional activities for the scientific community, with consideration to social and ethical aspects;</p> <p>Is able to undertake continuous independent professional development.</p> <p>The graduate of Bachelor's degree study programme:</p>	<p>Works independently in complicated and unpredictable situations;</p> <p>Takes responsibility for workgroups.</p>
--	-----------------------------------------------------------------------------------------------------------------------------	--	--	--------------------------------------------------------------------------------------------------------------------------------------------------------------------------------------------------------------------------------------------------------------------------------------------------------------------------------------------------------------------------------------------------------------------------------------------------------------------------------------------------------------------------------------------------------------------------------------------------------------------------------------------------------------------------------------------------------------------------------------------------------------------------------------------------------------------------------------------------------------------------------------------------------------------------------------------------------------------------------------------------------------------------------------------------------------------------------------------------------------------------------------------------------------------------	---------------------------------------------------------------------------------------------------------------------

				<p>Has a systematic overview of the basic concepts, theoretical principles, and research methods of the field of study;</p> <p>Recognises the theoretical schools, development trends, and current problems of the field of study;</p> <p>Is able to identify interdisciplinary relationships;</p> <p>Understands the scopes of application of different specialties of the field of study;</p> <p>Is able to formulate problems relating to the speciality and to analyse and evaluate different solutions;</p> <p>Is able to gather information independently by using appropriate methods and means and to interpret it critically and creatively;</p> <p>Is able to select and use appropriate technologies and methods when solving problems of the speciality;</p> <p>Is willing to participate in teamwork and lead;</p> <p>Has command of the communication skills and information and communication technologies necessary for work;</p> <p>Is able to explain orally or in written form in the language of instruction and at least one foreign language problems relating to the speciality, and to participate in professional discussions;</p> <p>Is willing to actively participate in civil society and demonstrate</p>	
--	--	--	--	----------------------------------------------------------------------------------------------------------------------------------------------------------------------------------------------------------------------------------------------------------------------------------------------------------------------------------------------------------------------------------------------------------------------------------------------------------------------------------------------------------------------------------------------------------------------------------------------------------------------------------------------------------------------------------------------------------------------------------------------------------------------------------------------------------------------------------------------------------------------------------------------------------------------------------------------------------------------------------------------------------------------------------------------------------------------------------------------------------------------------------------------------------------------------------------------------------------------------------------	--

				<p>tolerance towards the diversity of attitudes and values;</p> <p>Is able to evaluate the role of knowledge and the role and consequences of his or her professional activities in the scientific community, with consideration to scientific, social, and ethical aspects;</p> <p>Is able to apply the acquired knowledge and skills in work;</p> <p>Is able to continue studies and to undertake continuous independent professional development.</p>	
Level 7	<p>The owner of EstQF level 7 qualification:</p> <p>Has highly specialised knowledge; some of which is at the forefront of knowledge in the field of work or study, as the basis for original thinking and/or research;</p> <p>Has critical awareness of knowledge issues in a field and at the interface between different fields;</p> <p>Specialised problem-solving skills required in research</p>			<p>The graduate of Master’s degree study programme:</p> <p>Has a systematic overview and broad knowledge of the concepts, theories, and research methods of the field of study;</p> <p>Recognises theoretical development trends, current problems, and potential applications of the speciality;</p> <p>Has in depth knowledge in a narrower research field in the speciality;</p> <p>Is able to identify and create interdisciplinary connections;</p> <p>Is able to independently and creatively identify and formulate problems and /or research questions related to the speciality and is able to solve them with appropriate measures within given</p>	<p>The owner of EstQF level 7 occupational qualification:</p> <p>Integrates novel knowledge in his or her work area based on original thinking;</p> <p>Creates new knowledge within the framework of fixed time and in the condition of limited time;</p> <p>Creates new methodologies, methods and technologies;</p> <p>Solves unpredictable and complicated tasks</p>

	<p>and/or innovation in order to develop new knowledge and procedures and to integrate knowledge from different fields;</p> <p>Manages and transforms work or study contexts that are complex, unpredictable and require new strategic approaches;</p> <p>Takes responsibility for contributing to professional knowledge and practice and/or for reviewing the strategic performance of teams.</p>			<p>timeframes and within limited information, taking advantage of the knowledge of other fields as necessary;</p> <p>Is able to select and use appropriate technologies and methods when solving the problems of the speciality, and to model and/or assess the potential results;</p> <p>Is able to critically evaluate his or her activities when solving problems and/or research questions of the speciality;</p> <p>Is prepared to work in an area of activity that requires occupational qualifications, showing initiative, responsibility, leadership, and teamwork skills;</p> <p>Is able to hand down with competence his or her knowledge by teaching, instruction, or in another manner;</p> <p>Is able to present and reason orally or in written form in the language of instruction and a foreign language essential for his or her speciality the problems relating to the speciality, conclusions, and the underlying theories, and to participate in relevant discussions of both specialists and non-specialists;</p> <p>Is willing to actively participate in civil society and demonstrate tolerance towards the diversity of attitudes and values;</p> <p>Is able to act ethically in complex situations, be aware of the ethical</p>	<p>In science, innovation and other areas creating new knowledge;</p> <p>Initiates and plans activities and methods and analyses their short- and long-term consequences;</p> <p>Works independently in complicated and unpredictable situations requiring innovative approach;</p> <p>Is responsible for contributing to professional knowledge or professional activities;</p> <p>Is responsible for the strategic actions of teams.</p>
--	-----------------------------------------------------------------------------------------------------------------------------------------------------------------------------------------------------------------------------------------------------------------------------------------------------------------------------------------------------------------------------------------------------	--	--	-------------------------------------------------------------------------------------------------------------------------------------------------------------------------------------------------------------------------------------------------------------------------------------------------------------------------------------------------------------------------------------------------------------------------------------------------------------------------------------------------------------------------------------------------------------------------------------------------------------------------------------------------------------------------------------------------------------------------------------------------------------------------------------------------------------------------------------------------------------------------------------------------------------------------------------------------------------------------------------------------------------------------------------------------------------------------------------------------------------------------------------------------------------------------------------------------------------------------------------------------------------	--------------------------------------------------------------------------------------------------------------------------------------------------------------------------------------------------------------------------------------------------------------------------------------------------------------------------------------------------------------------------------------------------------------------------------------------

				<p>aspects, possibilities, restrictions and social role of his or her activities and be able to provide reasoned assessment in issues concerning his or her speciality;</p> <p>Is able to continue studies or participate in research, act as a specialist or developer in his or her field, including internationally;</p> <p>Is able to evaluate his or her need, and the needs of others, of continuing training and professional development, and have command of the effective methods necessary for independent study.</p>	
Level 8	<p>The owner of EstQF level 8 qualification:</p> <p>Has knowledge at the most advanced frontier in the field of work or study and at the interface between fields;</p> <p>Has the most advanced and specialised skills and techniques, including synthesis and evaluation, required to solve critical problems in research and/or innovation and to extend and redefine existing knowledge or professional practice;</p>			<p>The graduate of Doctoral degree study programme:</p> <p>Has broad knowledge and a systematic overview within his or her field of research and in-depth and up-to-date knowledge within a narrower sphere of the field of research;</p> <p>Understands the meaning and scope of the existing knowledge and research methods of the field of research and between fields so as to extend, reevaluate, and formulate them as necessary;</p> <p>Is able to independently and critically analyse, synthesise, and evaluate new and complex ideas relating to the speciality, and creatively and with scientific accuracy identify and formulate research questions;</p>	<p>The owner of EstQF level 8 occupational qualification:</p> <p>Works independently in complicated and unpredictable situations requiring innovative approach;</p> <p>Is responsible for contributing to professional knowledge or professional activities;</p> <p>Is responsible for the strategic actions of teams;</p> <p>Solves unique tasks in science, innovation and</p>

	<p>Demonstrates substantial authority, innovation, autonomy, scholarly and professional integrity and sustained commitment to the development of new ideas or processes at the forefront of work or study contexts including research.</p>			<p>Has command of research methods of his or her research field;</p> <p>Is able to conceive, design, implement, and critically evaluate research and development projects that lead to new knowledge and new procedural solutions;</p> <p>Is able to act independently in a work and study environment, which requires leadership and team work skills, innovative thinking, and the ability to make strategic decisions;</p> <p>Is able to hand down with competence his or her knowledge by teaching, instruction, or in another manner;</p> <p>Is able to present orally or in written form the problems and conclusions relating to the branch of science and his or her research, and the underlying theories, both to specialist audiences and in communication with non-specialists, and to present reasons and participate in relevant discussions in the language of instruction and a foreign language essential for his or her speciality, as well as to publish original scientific results in internationally pre-reviewed academic publications or, in art specialities, creative works for international audience;</p> <p>Is able to analyse social norms and relationships, comply therewith, and act to change them as necessary;</p> <p>Is able to provide scientific ethical assessments, show insight into the</p>	<p>other areas creating new knowledge;</p> <p>Initiates, plans and implements strategic research and development activities that enlarge the realm of work or knowledge or that result in considerable changes;</p> <p>Works independently in complicated, undefined situations requiring new strategic approach that require excellence;</p> <p>Is responsible for the planning and development of the work or knowledge area;</p> <p>Analyses and synthesises independently new and complicated professional ideas;</p> <p>Is responsible for the strategic performance of an organisation.</p>
--	--------------------------------------------------------------------------------------------------------------------------------------------------------------------------------------------------------------------------------------------	--	--	----------------------------------------------------------------------------------------------------------------------------------------------------------------------------------------------------------------------------------------------------------------------------------------------------------------------------------------------------------------------------------------------------------------------------------------------------------------------------------------------------------------------------------------------------------------------------------------------------------------------------------------------------------------------------------------------------------------------------------------------------------------------------------------------------------------------------------------------------------------------------------------------------------------------------------------------------------------------------------------------------------------------------------------------------------------------------------------------------------------------------------------------------------------------------------------------------------------------------------------------------------------------------------------------------------------------------------------	---------------------------------------------------------------------------------------------------------------------------------------------------------------------------------------------------------------------------------------------------------------------------------------------------------------------------------------------------------------------------------------------------------------------------------------------------------------------------------------------------------------------------------------------------------------------------------------------------

				<p>possibilities and limitations with science, the social role of science, and the responsibility of people in the use of scientific achievements;</p> <p>Has the ability to identify his or her need for further knowledge or skills and support the studies of others both in the context of education and science as well as on a wider social level.</p>	
--	--	--	--	--------------------------------------------------------------------------------------------------------------------------------------------------------------------------------------------------------------------------------------------------------------------------------------------------------------------------------------------------------------	--

